



POTATO PEELER PI-20

20 Kg. / 44 pounds load per cycle.



Timer (min-max): 0 ' - 6 '
Total loading: 550 W

External dimensions (WxDxH)

- ✓ Width: 433 mm
- ✓ Depth: 635 mm
- ✓ Height: 786 mm

External dimensions with stand

- ✓ Width with stand: 433 mm
- ✓ Depth with stand: 638 mm
- ✓ Height with stand: 1155 mm

Net weight: 38/36 Kg

Noise level (1m.): 70 dB(A)
Background noise: 32 dB(A)

Water Intake: 12 mm
Drain diameter: 80 mm

Crated dimensions
670 x 470 x 930 mm

AVAILABLE MODELS

1000618	Potato peeler PI-20 120/60/1
1000660	Potato peeler PI-20 230-400/50/3N
1000661	Potato peeler PI-20 230/50/1
1000662	Potato peeler PI-20 220-380/60/3N
1000663	Potato peeler PI-20 220/60/1

* Ask for special versions availability

SALES DESCRIPTION

Stainless steel construction commercial potato peeler. Also suitable to peel carrots and other similar products. 0-6 min. timer. Removable turntable for easy cleaning.

High capacity and production owing to lateral stirrers covered with silicon carbide abrasive (approved by NSF). Aluminium base plate lined with silicon carbide abrasive (approved by NSF). Construction in stainless steel.

- ✓ Auto-drag of waste to the drain.
- ✓ Energy efficiency owing to engine optimisation.
- ✓ Lifiable transparent polycarbonate cover, complete with locking and safety device.
- ✓ Aluminium door with hermetic seal and safety device.
- ✓ Waterproof control board (IP65): Improved reliability against moisture and water splash.
- ✓ Water inlet system with non-return air break.
- ✓ Auxiliary contact for external electric valve.
- ✓ 0-6min timer and possibility of continuous operation.
- ✓ Removable plate for easy cleaning.

OPTIONAL

- Stainless steel floor stand complete with filter with no-foam feature.

ACCESSORIES

- Stands for potato peelers
- Filters for potato peelers M / PI / PES

SPECIFICATIONS

Hourly production: 400 Kg / 480 Kg
Capacity per load: 20 Kg



DYNAMIC PREPARATION
COMMERCIAL POTATO PEELERS

product sheet
updated 06/10/2023



POTATO PEELER PI-20

20 Kg. / 44 pounds load per cycle.



DYNAMIC PREPARATION
COMMERCIAL POTATO PEELERS

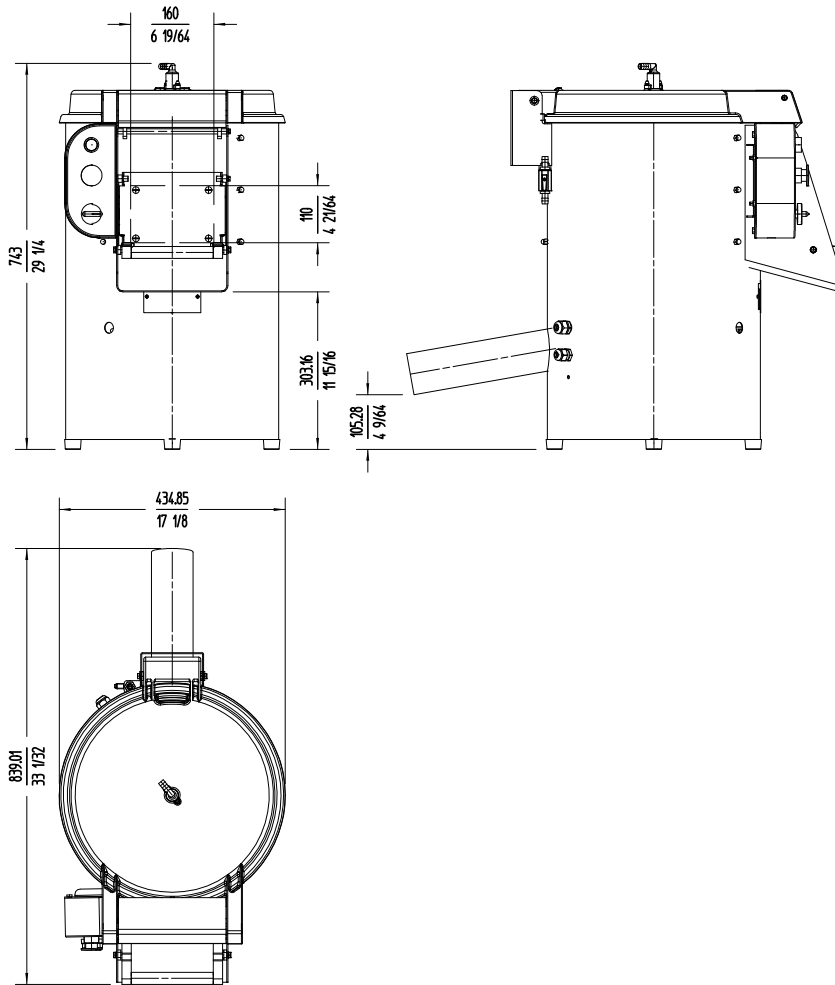

www.sammic.co.uk

Food Service Equipment Manufacturer

Unit 2, Trevanah Road
Troon Industrial Park
LE4 9LS - Leicester

uksales@sammic.com
Tel.: +44 0116 246 1900



Project	Date
Item	Qty
Approved	

product sheet
updated 06/10/2023