



POTATO PEELER PPC-12+

Output: 12 Kg. per cycle. Equipped with attachment drive to power accessories.



Timer (min-max): 0' - 6'
Plate speed: 317 rpm
Total loading: 550 W (1~) / 550 W (3~)

External dimensions (WxDxH)

- ✓ Width: 395 mm
- ✓ Depth: 700 mm
- ✓ Height: 503 mm

External dimensions with stand

- ✓ Width with stand: 411 mm
- ✓ Depth with stand: 700 mm
- ✓ Height with stand: 1015 mm

Net weight: 38 Kg

Noise level (1m.): 70 dB(A)
Background noise: 32 dB(A)

AVAILABLE MODELS

1000440	Potato peeler PPC-12+	230-400/50/3	·550W
1000441	Potato peeler PPC-12+	230/50/1	·550W
1000442	Potato peeler PPC-12+	220-380/60/3	
1000443	Potato peeler PPC-12+	220/60/1	
1000446	Potato peeler PPC-12+	440/60/3	

* Ask for special versions availability

SALES DESCRIPTION

Aluminium made potato peeler.

Aluminium body potato peeler. Abrasive peeling. The abrasive is highly resistant and long lasting.

- ✓ Base Plate and chamber walls lined with abrasive.
- ✓ Aluminium body.
- ✓ Equipped with attachment drive to power accessories.
- ✓ Directable cylinder.
- ✓ Integral control panel complete with on/off push buttons and a 0-6 minute timer.

INCLUDES

- ✓ Attachment drive to power accessories.

OPTIONAL

- Stainless steel floor stand.
- Filter with no-foam feature.
- Vegetable preparation attachment CR-143.
- Potato masher attachment P-132.
- Meat mincer attachment HM-71.
- Water inlet kit (2003971).

ACCESSORIES

- Vegetable preparation attachment CR-143
- Meat mincer attachment HM-71
- Potato masher attachment P-132
- Stands for potato peelers
- Filters for potato peelers PP / PPC

SPECIFICATIONS

Hourly production: 220 Kg / 300 Kg
Capacity per load: 12 Kg

DYNAMIC PREPARATION
COMMERCIAL POTATO PEELERS

product sheet
updated 24/10/2022



SAMMIC, S.L.
Bassaře, 1 - 20720 Azzovita
www.sammic.com



POTATO PEELER PPC-12+

Output: 12 Kg. per cycle. Equipped with attachment drive to power accessories.



DYNAMIC PREPARATION
COMMERCIAL POTATO PEELERS

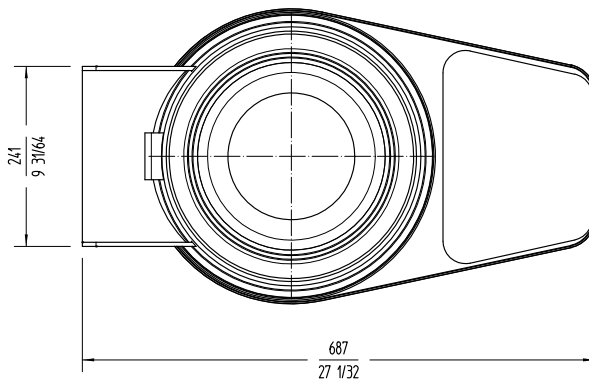
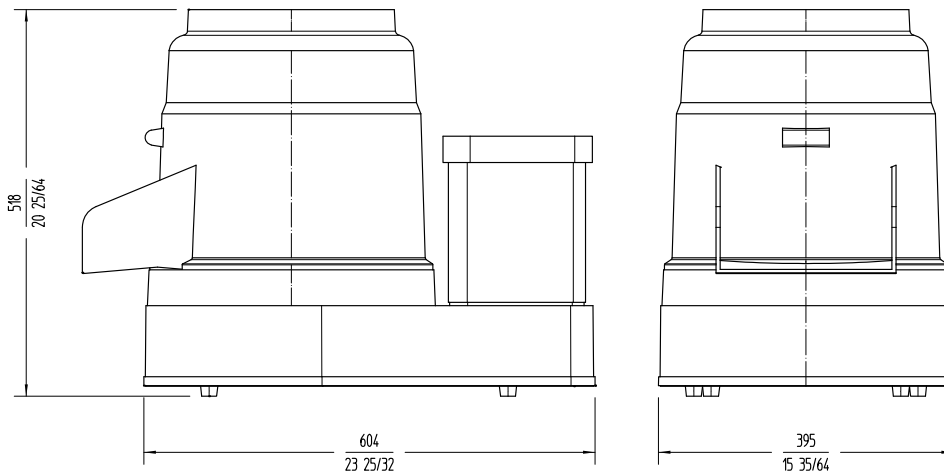

www.sammic.co.uk

Food Service Equipment Manufacturer

Unit 2, Trevanth Road

Troon Industrial Park

LE4 9LS - Leicester

uksales@sammic.com

Tel.: +44 0116 246 1900



Project

Date

Item

Qty

Approved

product sheet
updated 24/10/2022