



CUTLERY DRYER-POLISHER SAS-6001

Floorstanding machine with motor brake and outlet fan.



WARE WASHING
CUTLERY POLISHERS



FEATURES AND BENEFITS

- ✓ Dries, polishes and removes lime scale stains from cutlery after washing.
- ✓ Fully automatic.
- ✓ Stainless steel body and polishing tank.
- ✓ Rounded cutlery carousel, avoiding cutlery jams.
- ✓ Economy: saves on personnel costs and quick return of investment.
- ✓ Speed: hourly output of up to 8,000 pieces.
- ✓ Hygiene: the germicidal UVC-ray lamp sterilises both the cutlery and the polishing product.

INCLUDES

- ✓ Germicidal UVC-ray lamp.
- ✓ Outlet fan.
- ✓ Motor brake.

SALES DESCRIPTION

Output: up to 8000 pieces per hour.



www.sammic.co.uk
 Food Service Equipment Manufacturer
 Unit 2, Trevanah Road
 Troon Industrial Park
 LE4 9LS - Leicester
 uksales@sammic.com
 Tel.: +44 0116 246 1900



Project	Date
Item	Qty
Approved	

product sheet
updated 06/03/2018



CUTLERY DRYER-POLISHER SAS-6001

Floorstanding machine with motor brake and outlet fan.



SPECIFICATIONS

Hourly production (pieces): 5000 - 8000

Loading

- ✓ Motor power: 300 W
- ✓ Element power: 900 W
- ✓ Uvc lamp power: 8 W
- ✓ Fan power: 50 W

External dimensions (WxDxH)

- ✓ Width: 630 mm
- ✓ Depth: 693 (800) mm
- ✓ Height: 783 mm

Net weight: 130 Kg

Noise level (1m.): 70 dB(A)

Noise level (1m.) when loaded: 90 dB(A)

Background noise: 25 dB(A)

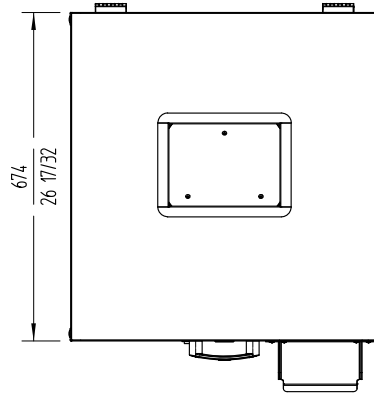
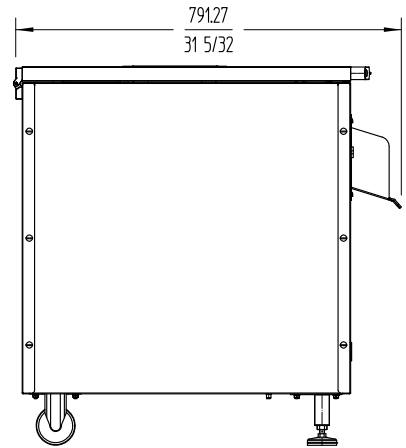
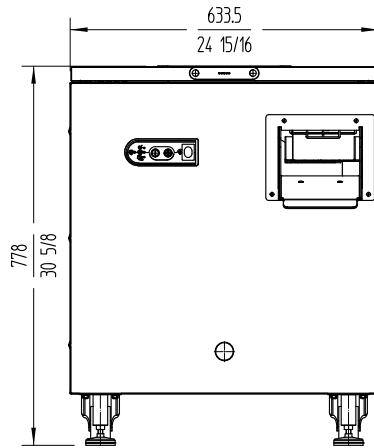

AVAILABLE MODELS

1370044 Cutlery dryer-polisher SAS-6001 230/50/1

1370048 Cutlery dryer-polisher SAS-6001 230-400/50/3N

* Ask for special versions availability

ACCESSORIES

Polishing product

Front Wheel Kit

WARE WASHING
CUTLERY POLISHERS



www.sammic.co.uk

Food Service Equipment Manufacturer

Unit 2, Trevanah Road
Troon Industrial Park
LE4 9LS - Leicester

uksales@sammic.com
Tel.: +44 0116 246 1900



Project

Date

Item

Qty

Approved

product sheet
updated 06/03/2018