



VACUUM SEALER SE-420

Tabletop model. 20 m³/h. 420 mm.



FOOD PRESERVATION AND SOUS-VIDE
VACUUM PACKING MACHINES - "SENSOR" LINE



FEATURES AND BENEFITS

- ✓ Powered by Busch.
- ✓ Vacuum controlled by sensor.
- ✓ Vacuum PLUS.
- ✓ Digital keyboard.
- ✓ Control panel equipped with display indicating the exact vacuum percentage.
- ✓ "Pause" button to marinate food.
- ✓ Safe liquid packing thanks to sensor control.
- ✓ Double seal.
- ✓ Cordless sealing bar.
- ✓ Bag-sealing programme.
- ✓ Pulse-controlled decompression.
- ✓ Vac-Norm ready with Automatic decompression.
- ✓ Stainless steel body and chamber. Deep-drawn chamber.
- ✓ Damped transparent lid of highly durable polycarbonate.
- ✓ Dry-oil programme for drying the pump.
- ✓ Working hours counter for oil changes.
- ✓ Safety system with protection against vacuum failure.

SALES DESCRIPTION

420 mm. sealing bar.
 20 m³/h Busch vacuum pump.
 Vacuum controlled by sensor.

INCLUDES

- ✓ Sensor Controls
- ✓ Up to 10 seconds of extra vacuum pull
- ✓ Soft air function
- ✓ Dry oil cycle
- ✓ BUSCH pump
- ✓ NSF Approved
- ✓ Clear methacrylate lid
- ✓ Filling plate



www.sammic.co.uk
 Food Service Equipment Manufacturer
 Unit 2, Trevanth Road
 Troon Industrial Park
 LE4 9LS - Leicester
 uksales@sammic.com
 Tel.: +44 0116 246 1900



Project	Date
Item	Qty
Approved	



VACUUM SEALER SE-420

Tabletop model. 20 m³/h. 420 mm.



SPECIFICATIONS

Pump capacity: 20 m³/h
 Bar length: 420 mm
 Total loading: 750 W
 Vacuum pressure (maximum): 2 mbar

Internal dimensions

- ✓ Width: 430 mm
- ✓ Depth: 415 mm
- ✓ Height: 180 mm

External dimensions (WxDxH)

- ✓ Width: 484 mm
- ✓ Depth: 529 mm
- ✓ Height: 448 mm
- Net weight: 70 Kg
- Noise level (1m.): -- dB(A)
- Background noise: 32 dB(A)

Crated dimensions

- 600 x 600 x 610 mm
- Gross weight: 62 Kg.

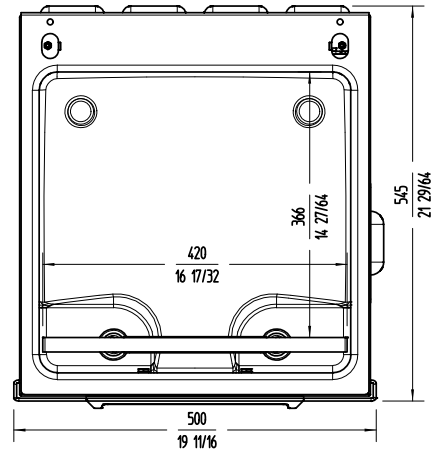
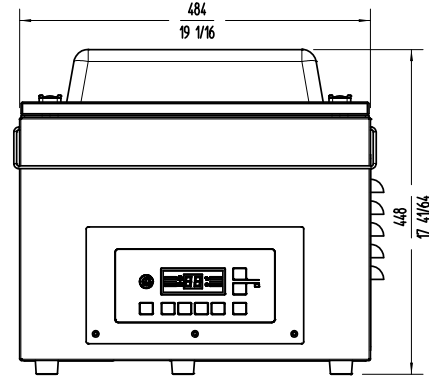
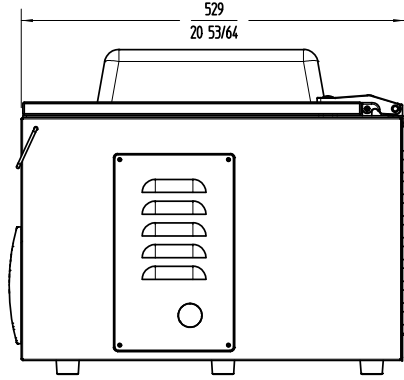

AVAILABLE MODELS

1140638 Vacuum packing machine SE-420 230/50-60/1

* Ask for special versions availability

ACCESSORIES

- Bag cutting kits
- Vac-norm containers
- Filling plates
- Smooth bags for vacuum packing
- Liquid insert plates
- Trolley for vacuum packing machines
- Vac-norm external vacuum kits

FOOD PRESERVATION AND SOUS-VIDE
VACUUM PACKING MACHINES - "SENSOR" LINE



www.sammic.co.uk
 Food Service Equipment Manufacturer
 Unit 2, Trevanah Road
 Troon Industrial Park
 LE4 9LS - Leicester
 uksales@sammic.com
 Tel.: +44 0116 246 1900



Project	Date
Item	Qty
Approved	