

7.7 - LUBRICATION OF SLIDING GUIDES

Occasionally put a few drops of oil (using the oil dispenser shipped with the machine) on the round bar which slides the carriage back and forth. Do so through the hole (OIL) on the side with the thickness knob.

7.8 - CONTROL PANEL LABEL

Over time the pushbutton label may become stained and/or damaged. In that case, call the "Customer Assistance Center" to replace it.

CHAP. 8 - DISASSEMBLY

8.1 - OUT OF SERVICE

If you decide to put the machine out of service for whatever reason, make sure it is unusable by any and all personnel: **unplug and switch off the power supply.**

8.2 - WEEE Electronic-disposal, waste electrical and electronic equipment



In accordance with article 13 of Legislative Decree n. 151 of 25 July 2005, "Implementation of Directives 2002/95/CE, 2002/96/EC and 2003/108/EC, regarding the reduction of the use of hazardous substances in electric and electronic equipment, as well as waste disposal".

The symbol of the checked box on the equipment or the packaging indicates that the product must be disposed of separately, not with regular waste, at the end of the product's working life. Recycling of this machine at the end of its working life is organized and carried out by the manufacturer. Any user who wishes to dispose of this machine must contact the manufacturer and follow the procedure that has been put in place for the recycling of the machine at the end of its working life.

Appropriate collection of the machine for recycling and environmentally safe disposal contributes to avoiding possible harm to health and the environment and favors reuse and/or recycling of the material the machine is made of.

Illegal disposal of the machine by the holder will be penalized by the administrative sanctions provided for by law.

**CUSTOMER ASSISTANCE CENTER
AUTHORIZED DEALERS**

Professional CE food slicers:

SMR 220 - 250

INSTRUCTION, USE AND MAINTENANCE MANUAL

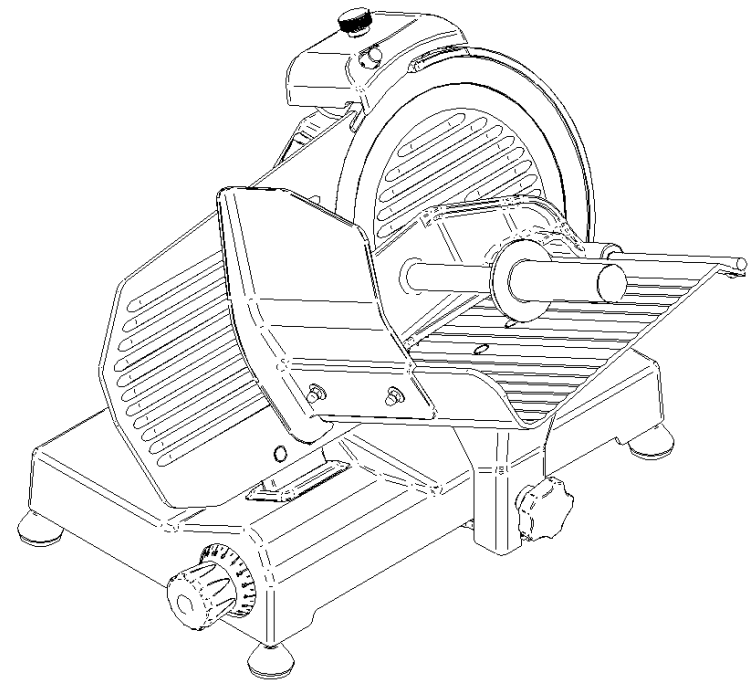

Ed. 12/2013

INTRODUCTION

- This manual has been written to provide the **customer** with all information and relevant regulations about the machine, as well as use and maintenance instructions to ensure effective use so the machine will remain fully efficient over time.
- This manual must be given to people in charge of the use and periodic maintenance of this machine.

CONTENTS

CHAP. 1 - INFORMATION ABOUT THE MACHINE	page 4
1.1 - GENERAL PRECAUTIONS	
1.2 - SAFEGUARDS INSTALLED ON THE MACHINE	
1.2.1 - mechanical safeguards	
1.2.2 - electrical safeguards	
1.3 - DESCRIPTION OF THE MACHINE	
1.3.1 - general description	
1.3.2 - manufacturing characteristics	
1.3.3 - parts	
CHAP. 2 - TECHNICAL DATA	page 7
2.1 - DIMENSIONS, WEIGHT, CHARACTERISTICS...	
CHAP. 3 - RECEIPT OF THE MACHINE	page 8
3.1 - SHIPMENT OF THE MACHINE	
3.2 - CHECKING PACKAGE UPON RECEIPT	
3.3 - DISPOSAL OF PACKAGING	
CHAP. 4 - INSTALLATION	page 9
4.1 - PLACEMENT OF THE MACHINE	
4.2 - POWER CONNECTION	
4.2.1 - food slicer with AC motor	
4.3 - WIRING DIAGRAMS	
4.3.1 - AC electrical system diagram	
4.4 - TESTING	
CHAP. 5 - USE	page 10
5.1 - COMMANDS	
5.2 - LOADING AND CUTTING	
5.3 - SHARPENING THE BLADE	
CHAP. 6 - REGULAR CLEANING	page 13
6.1 - GENERAL	
6.2 - CLEANING THE MACHINE	
6.2.1 - cleaning the food carriage plate	
6.2.2 - cleaning the blade, the internal blade cover and the ring	
6.2.3 - cleaning the blade sharpener	
6.2.4 - cleaning the support plate	

6.2.3 - cleaning the blade sharpener

Rub the wheels with a brush. The wheels must always be in the safeguard position with the wheels facing opposite the blade.

6.2.4 - cleaning the support plate

To remove the support plate (see FIG. n°13), simply unscrew the two screws (a) which fix it in place.



FIG. n° 13 - Support plate image

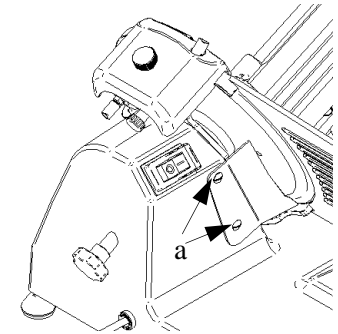

At this point, clean the support plate with water and neutral detergent (PH 7).

CHAP. 7 - MAINTENANCE

7.1 - GENERAL

Before carrying out any maintenance operation, it is necessary to:

- a) detach the power cord from the power supply to completely separate the machine from the electrical system;
- b) turn the food guide knob to "0" position;

7.2 - BELT

The belt does not require any adjustment. Generally after 3-4 years it must be replaced; in which case, call the "Customer Assistance Center".

7.3 - FEET

Over time the feet can deteriorate and lose their elasticity, which will decrease the stability of the machine. Replace them by calling the "Customer Assistance Center".

7.4 - POWER CABLE

Periodically check the wear and tear of the power cord and if necessary, call the "Customer Assistance Center" to replace it.

7.5 - BLADE

Check that, after many sharpenings, the blade diameter has not decreased by more than 10 mm compared to the original diameter. For substitutions, call the "CUSTOMER ASSISTANCE CENTER".

7.6 - WHEELS

Check that the wheels retain their abrasiveness during sharpening. If not, they must be replaced to avoid damaging the blade; in which case, call the "Customer Assistance Center".

6.2.2 - cleaning the blade, the internal support plate and the ring

Unscrew the knob for the blade guard stay rods (1) (*Fig.n°11*) in order to remove the internal blade guard (2).

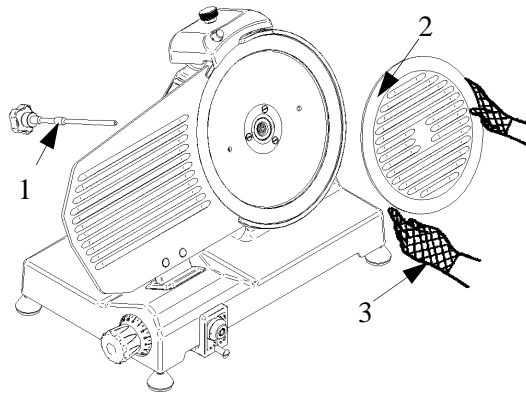

FIG. n°11 - Unfasten the blade guard

WARNING: cleaning the blade must be done while wearing a pair of metal gloves (*ref. 3 Fig. n° 11*) and using a moist cloth.

To clean the surface opposite the blade and the ring, the blade must be removed (*Fig. n°12*) from the food slicer.

To remove the blade, follow these steps:

- 1) unfasten the internal blade guard (*ref. n°2 - FIG. n°11*);
- 2) remove the blade sharpener (a) and open the food guide by using the thickness knob, just enough to allow the template (b) to adhere well to the blade;
- 3) unscrew the three screws (f), according to the model, which fix the blade in place;
- 4) place the Plexiglas template on the blade so that the slit in the template matches up with the ring (c);
- 5) match the axle of the two holes (d) in the blade with the two knobs (e) on the template, making the blade turn until reaching the desired position;
- 6) tighten the two knobs (e) without over-tightening.

At this point, clean everything with water and neutral detergent (PH 7).

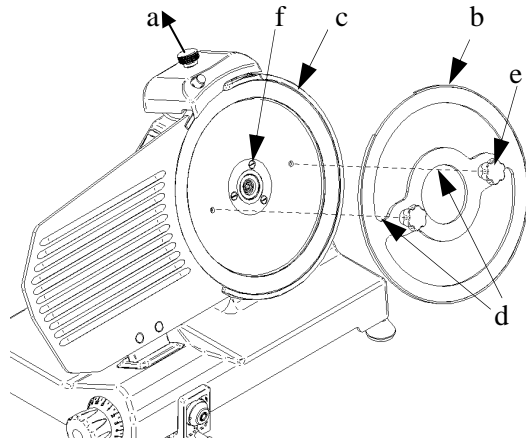

FIG. n°12 - Position the template to remove the blade

CHAP. 7 - MAINTENANCE

page 15

- 7.1 - GENERAL
- 7.2 - BELT
- 7.3 - FEET
- 7.4 - POWER CABLE
- 7.5 - BLADE
- 7.6 - WHEELS
- 7.7 - LUBRICATING SLIDING GUIDES
- 7.8 - CONTROL PANEL LABEL

CHAP. 8 - DISASSEMBLY

page 16

- 8.1 - OUT OF SERVICE
- 8.2 - WEEE Electronic-disposal, waste electrical and electronic equipment

CHAP. 1 - INFORMATION ABOUT THE MACHINE

1.1 - GENERAL PRECAUTIONS

- The food slicer must only be used by personnel trained in its usage and who are perfectly familiar with all of the safety regulations contained in this manual.
- In the event of alternating personnel, provide sufficient time for training.
- Even if safeguards are installed on dangerous areas of the machine, avoid putting hands close to the blade or other moving parts.
- Before carrying out any cleaning or maintenance procedures, completely detach the power cord from the power supply.
- When cleaning or performing maintenance on the food slicer (in which case the safeguards have been removed), pay extreme attention to the residual risks of injury.
- During maintenance and cleaning, concentrate only on the task at hand.
- Frequently check to state of the power cord. A worn out or damaged cord is extremely dangerous, as it can lead to electrical injury.
- If the food slicer malfunctions or does not function well, do not use it. Do not attempt to repair the machine, but contact the "Customer Assistance Center"; the contact information for which is located on the back of this manual.
- The slicer was designed to cut meat which is not frozen and does not contain bone. Any other use is considered inappropriate and therefore can be dangerous.
- **Never cut nearly finished pieces of meat without using the food arm.**
- **Do not place any part of your body where it can come into direct contact with the blade.**
- The manufacturer refuses any and all responsibility in the following cases:
 - ⇒ unauthorized personnel tamper with the machine;
 - ⇒ components are replaced with non-original parts;
 - ⇒ the instructions in this manual are not **carefully** followed;
 - ⇒ the machine's surfaces are treated with inappropriate materials.

1.2 - SAFEGUARDS INSTALLED ON THE MACHINE

1.2.1 - electrical safeguards

Regarding mechanical safeguards, the food slicer described in this manual is in accordance with the directives **CEE 2006/42**.

These safeguards include (see 1.3.3):

- internal blade guard;
- ring;
- blade sharpener;
- food arm;
- food arm knob with locking ring and spacer;
- blade cover;
- carriage removable only when the food guide is in "0" position, at stroke end and toward the operator side.

CHAP. 6 - REGULAR CLEANING

6.1 - GENERAL

- Cleaning the machine should be done once per day or, if necessary, more frequently.
- Cleaning all parts of the machine which come into direct or indirect contact with food must be done scrupulously.
- The food slicer must not be cleaned with a pressure jet cleaner, but with water and neutral detergent (PH 7). **Every other type of detergent is prohibited.** Do not use utensils, brushes, etc., because they can damage the surface of the machine.

Before carrying out any cleaning operation, it is necessary to:

1) detach the power cord from the power supply to completely separate the machine from the electrical system;

2) turn the food guide knob to "0" position;

WARNING: Beware of the residual risks caused by the cutting and barbed components of the machine.

6.2 - CLEANING THE MACHINE

6.2.1 - cleaning the carriage plate (Fig. n°10)

The carriage (plate + arm + carriage holder) is easily removable:

- with the knob at "0" position (1);
- with the carriage (2) at the end of a stroke (a) on the side of the controls;
- unscrew the carriage plate blocking knob (3) and pull the carriage upwards (b);
- once removed, the carriage plate can be cleaned properly with warm water and neutral detergent (PH7).

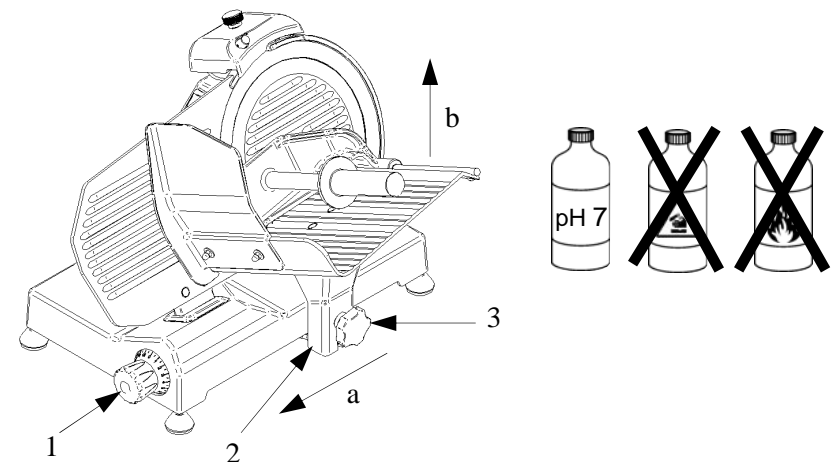

FIG. n°10 - Unfasten the carriage

5.3 - SHARPENING THE BLADE (Fig. n°9 a-b-c)

WARNING: Before sharpening the blade, pay careful attention to the **RESIDUAL RISKS** (chapter 1.2.2) related to the danger of being cut if the instructions below are not followed exactly.

Sharpening the blade should be done periodically, as soon as cutting precision decreases. To do so, follow these steps:

1. detach the power cord from the power supply and clean the blade with denatured alcohol to remove grease;
2. loosen the blade sharpener blocking knob (1), lift (a) the blade sharpener (2) until it stops and then rotate it 180° (b) (Fig. 9a).
3. Let it go until it reaches the end of the stroke (c) so that the blade is between the two wheels. Tighten the blade sharpener blocking knob;
4. start the machine by using the power on button "I" (ON);
5. push the button (3) (Fig. n°9b), let the blade rotate while in contact with the wheel for approximately 30-40 sec. so that a light flash forms at the edge of the blade;
6. for 3-4 sec. push the buttons (3 and 4) simultaneously, then let both of them go at the same moment (Fig. n°9c);
7. after sharpening the blade, it's best to clean the wheels (see 6.2.3);
8. when the entire process is finished, replace the blade sharpener in its original position by reversing the previous procedure.

N.B. Do not allow the blade to flash for more than 3-4 sec. to avoid damaging the blade edge.

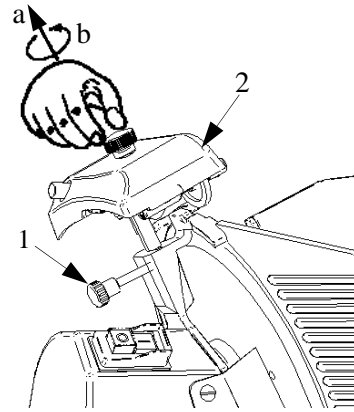

FIG. n°9a

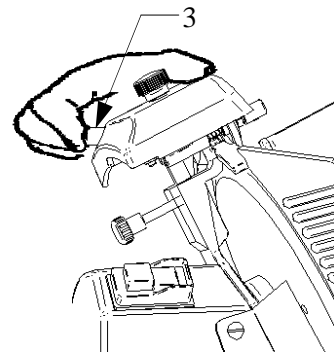

FIG. n°9b

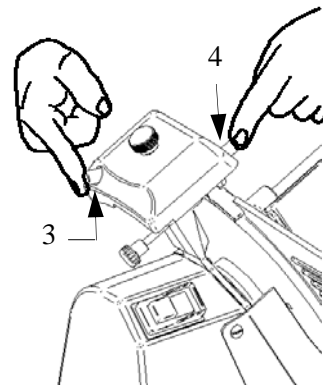

FIG. n°9c

1.2.2 - electrical safeguards

Regarding electrical safeguards, the food slicer described in this manual is in accordance with the directives **CEE 2006/95, 2004/108** and mod. **2006/42**.

The food slicer is equipped with:

- a micro-switch which turns off the machine if the blade guard's stay rods are removed (see Fig. n°1), and does not allow it to be turned on until the guard is locked into the closed position.
- control circuit relay, which requires the machine to be restarted in case the power source accidentally goes out.

Although professional CE food slicers are equipped with the all electrical and mechanical safety measures (during the operational, cleaning and maintenance phases) as required by law, **RESIDUAL DANGERS still exist which are impossible to completely eliminate. In this manual they are identified with WARNING.** These refer to the risk of cuts, bruises, etc., caused by the blade or other machine parts.

1.3 - DESCRIPTION OF THE MACHINE

1.3.1 - general description

Professional CE food slicers were designed and built by our company for the specific purpose of slicing food products (in particular meats) and guarantee:

- maximum safety during use, cleaning and maintenance;
- maximum hygiene, thanks to careful selection of materials and to the elimination of rough edges on the parts of the machine which come in contact with the food; thereby enabling easy total cleaning and disassembly;
- maximum cutting precision thanks to the cam mechanism;
- all components are stable and robust;
- low noise emissions thanks to the belt transmission;
- easy to handle.

1.3.2 - manufacturing characteristics

The food slicer is built of die cast food-grade aluminum alloy (EN-AB 44100) with food-grade paint. This guarantees hygienic contact with the food and resistance to acids, salts and oxidation.

The steel blade 100 Cr6 (chrome-plated) is ground and tempered to ensure whole and precise cutting of products, even after sharpening. The other components are in ABS and steel AISI 430 or 304.

1.3.3 - Parts

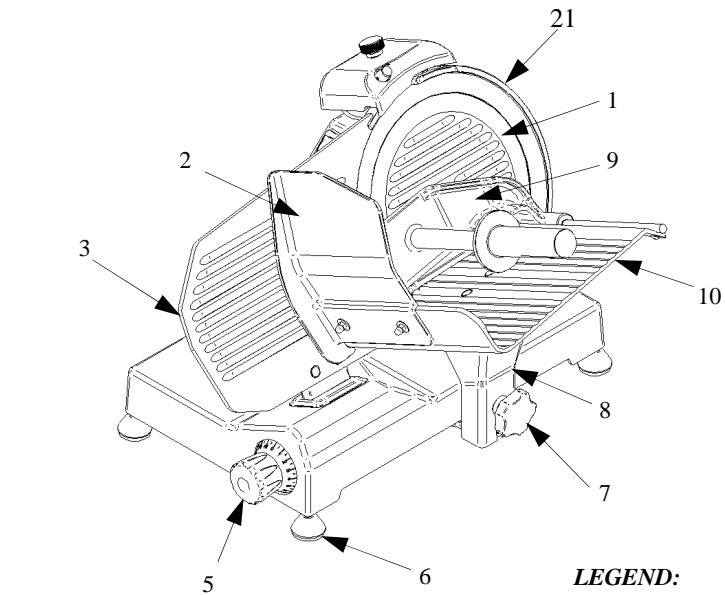

LEGEND:

1. Internal blade guard
2. Blade cover
3. Food guide
4. Circuit breaker
5. Thickness control knob
6. Feet
7. Carriage blocking knob
8. Carriage holder
9. Food arm
10. Food carriage plate
11. Blade sharpener
12. Blade sharpener blocking knob
13. Blade guard stay rods
14. Power supply cord
15. Base
16. Technical identification plate
17. Food guide support
18. Blade
19. Support plate
20. Food arm knob
21. Ring

FIG. n°1 - General image of food slicer

5.2 - LOADING AND CUTTING

WARNING: The food to be sliced must be loaded onto the carriage only when the knob is in "0" position and the motor is off, and while paying careful attention to the blade and the barbs.

Follow these steps:

1. once the food has been loaded onto the carriage, touching the food guide, block it with the barbed food arm;
2. regulate the thickness of the slice by using the thickness knob;
3. stand properly in order to operate the machine without incident; place your right hand on the food arm knob, then the left hand next to the support plate (**without coming in contact with the blade**); your body must be perpendicular to the work plane (Fig. n°7a). **WARNING:** Do not position your body in such a way that any part comes into direct contact with the blade (example Fig n°7b);
4. switch on the power on button "I" (ON) Fig. n°6;
5. push the carriage (carriage plate + food arm + carriage holder) gently towards the blade, without applying any pressure on the food with the food arm. It pushes against the food guide on its own (by force of gravity). The food will enter smoothly into the blade and the slice, guided by the support plate, will detach and fall onto the collection tray (Fig. n°8);
6. avoid working the food slicer when it is empty;
7. when finished cutting, stop the machine by using the power off button "0" (OFF) Fig. n°6 and place the knob in the "0" position;
8. sharpen the blade as soon as the cut surface of the food presents a frayed or rough edge, which means cutting has become difficult (see 5.3).

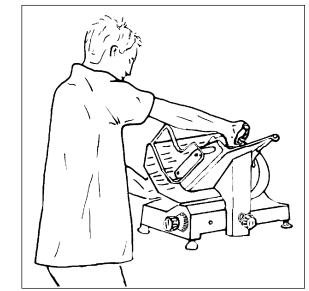

FIG. n°7a - Correct position



FIG. n°7b - Wrong position

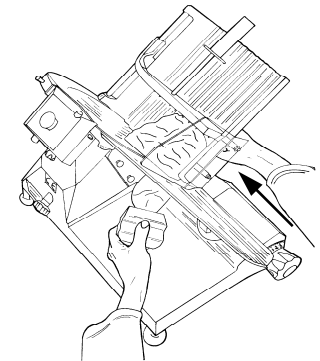

FIG. n°8 - Cutting

4.3 - WIRING DIAGRAMS

4.3.1 - diagram of AC electric motor (Fig. n°5)

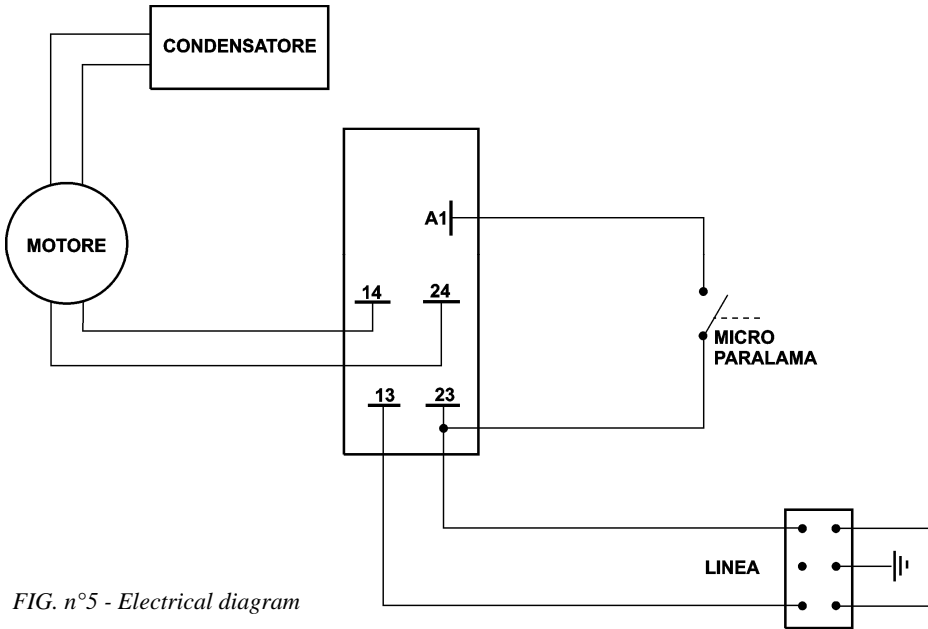

FIG. n°5 - Electrical diagram

4.4 - TESTING

Before testing the machine, make sure the carriage plate is well blocked. Then test the machine following these steps:

1. test the power on button "I" (ON) and the power off button "O" (OFF), Fig. n°6;
2. check that the carriage plate and the food arm slide properly;
3. check that the food guide works and regulates properly by using the numbered knob;
4. check that the blade sharpener works properly (see paragraphs 5.3, Fig. n° 9a-b-c);
5. check that the carriage plate can only be disassembled when the knob is in the "0" position, and after disassembly, the knob stays in that position;
6. check that the machine stops working if the blade guard's stay rods are loosened.

CHAP. 5 - USE OF THE MACHINE

5.1 - COMMANDS

The commands are displayed on the operator's left side above the support plate on the base.

- 1 Power on button "I"(ON).
- 2 Power off button "O"(OFF).

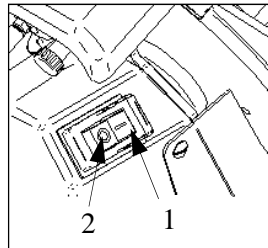

FIG. n°6 - Position of commands

CHAP. 2 - TECHNICAL DATA

2.1 - DIMENSIONS, WEIGHT, CHARACTERISTICS ...

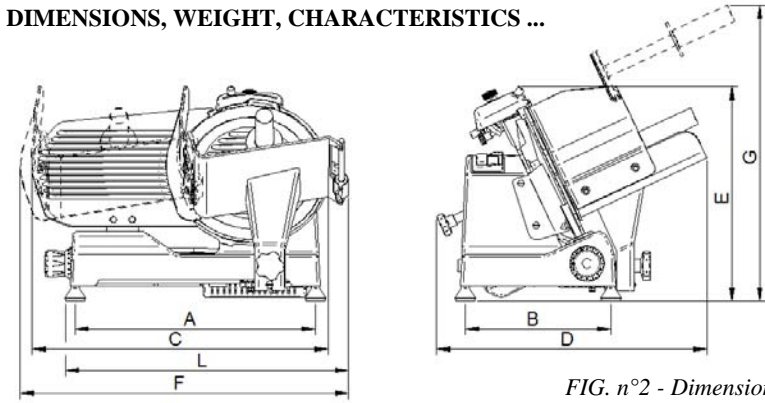

FIG. n°2 - Dimensions diagram

TAB. n°1 - DIMENSIONS AND TECHNICAL CHARACTERISTICS

MODEL	U.m.	220	250
ø Blade	mm	220	250
Motor	W / Hp	132 / 0,18	132 / 0,18
Power supply		230V / 50Hz	
Cutting thickness	mm	13	13
Sliding carriage	mm	247	247
Plate dimension	mm	225x240	225x240
A / B	mm	405 / 245	405 / 245
C / D / E	mm	480 / 460 / 365	500 / 460 / 365
F / G	mm	555 / 466	555 / 460
L	mm	495	480
X / Y	mm	220 / 135	215 / 150
H / W	mm	170 / 160	185 / 175
Net weight	Kg	15	15,5
Noise level	dB	≤ 60	≤ 60

