



IMMERSION CIRCULATOR SMARTVIDE 8 PLUS

Max. capacity: 56 lt./14 gal. Bluetooth connectivity for HACCP.



FEATURES AND BENEFITS

Portable precision cooker with stirrer for up to 56 lt. / 14 gal. containers. Designed for chefs, developed with chefs.

- ✓ The thick stainless steel, robust construction guarantees commercial performance.
- ✓ SmartVide guarantees cooking at a **precisely controlled temperature** while preserving the quality of the product, enhancing flavour and texture. Equipped with a highly precise temperature control system to obtain extremely consistent results. An **optional core probe** allows getting an even more precise control.
- ✓ Allows cooking food in their own juice and using this juice immediately after cooking to **enhance flavours**.
- ✓ Marinates and macerates an ingredient in **half the time**.
- ✓ **Infuses and flavours** oil, fat or other products applying the controlled temperature technique.
- ✓ Increases **profits** due to lack of product shrink.
- ✓ Requires **very little hands-on time**, allowing the Chef to do other tasks while the product is being cooked. Just program temperature and time, SmartVide will do the rest. 4 buttons and a full-colour TFT display that offers **all the information at a glance** makes operation a child's play. Moreover, thanks to Bluetooth connectivity, SmartVide 8 Plus allows for an interchange of important data to improve the chef's performance.
- ✓ SmartVide8 is **portable**: thanks to their thick, stainless steel, ergonomic handle, SmartVide8 can be taken from a container to another easily. Additionally, the bag supplied with the circulator allows easy transport - wherever the Chef goes.
- ✓ SmartVide8 Plus allows for an **effective HACCP control**. Thanks to Bluetooth connectivity, it is possible to export or print cooking results at the end of each cycle.

SALES DESCRIPTION

Commercial high-precision sous-vide cooker. Reliable, user-friendly, portable.

With cutting-edge features that allow interchange of important data to improve the chef's experience and to allow an effective HACCP control thanks to Bluetooth connectivity.

Interchangeable between °C and °F.

4 user-friendly control buttons.

INCLUDES

- ✓ Stainless steel handle and panel.
- ✓ Bluetooth connectivity.
- ✓ Transport bag.

ACCESSORIES

- Needle Probe for sous-vide
- SmartVide transport bag cookers
- Probe Foam Seal
- Insulated tank for SmartVide immersion circulator
- Lid for SmartVide
- Floating balls for SmartVide



www.sammic.co.uk

Food Service Equipment Manufacturer

Unit 2, Trevanah Road
Troon Industrial Park
LE4 9LS - Leicester

uksales@sammic.com
Tel.: +44 0116 246 1900



Project	Date
Item	Qty
Approved	

FOOD PRESERVATION AND SOUS-VIDE
SOUS-VIDE COOKERS

product sheet
updated 01/08/2018



IMMERSION CIRCULATOR SMARTVIDE 8 PLUS

Max. capacity: 56 lt./14 gal. Bluetooth connectivity for HACCP.



SPECIFICATIONS

Temperature

Display precision: 0.01 °C

Range: 5 °C - 95 °C

Permissible ambient temperature: 5 °C - 40 °C

Time

Resolution: 1 '

Cycle duration: 1 ' - 99 h

General features

Maximum recipient capacity: 56 l

Bluetooth connectivity: Yes

HACCP-ready: Yes

Recipe memory: 20

Total loading: 2000 W

Submersible part dimensions: 117 mm x 110 mm x 147 mm

External dimensions (WxDxH): 124 mm x 140 mm x 360 mm

Net weight: 4.2 Kg

Crated dimensions

440 x 190 x 310 mm

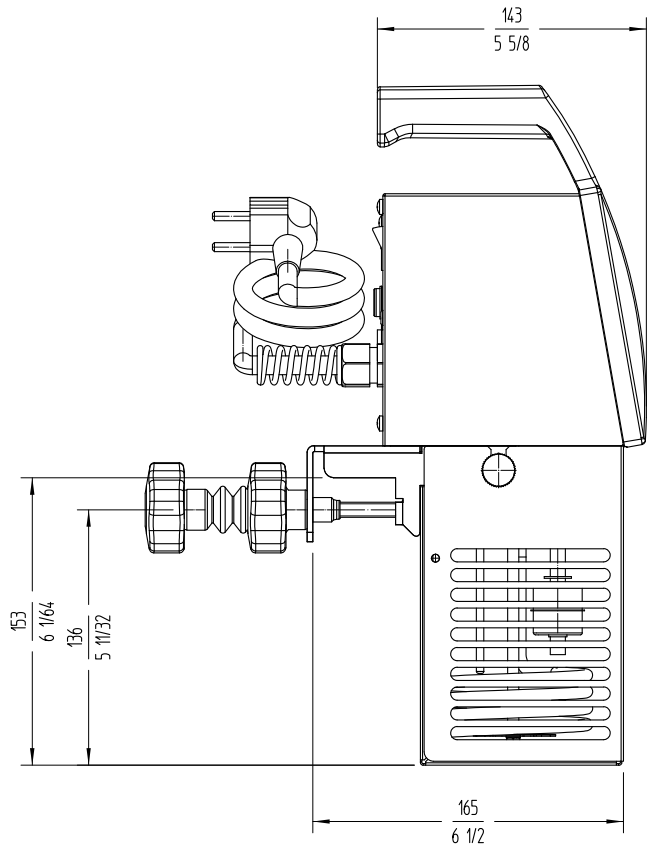
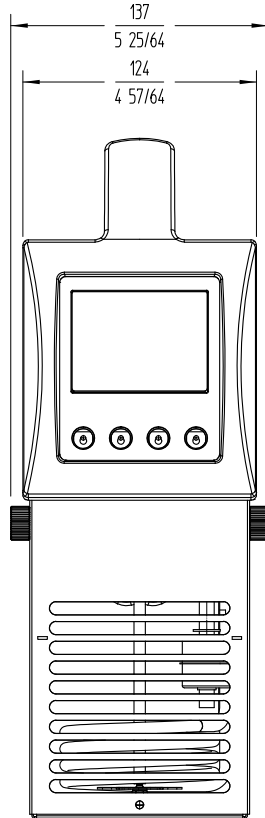

AVAILABLE MODELS

1180003 SmartVide8 Plus 230/50-60/1 UK

* Ask for special versions availability



www.sammic.co.uk

Food Service Equipment Manufacturer

Unit 2, Trevanth Road
Troon Industrial Park
LE4 9LS - Leicester

uksales@sammic.com
Tel.: +44 0116 246 1900



Project

Date

Item

Qty

Approved

product sheet
updated 01/08/2018

FOOD PRESERVATION AND SOUS-VIDE
SOUS-VIDE COOKERS