



F59/440 - IMC SMP25 Floor-mounted Potato Peeler - 3 Phase - W 642 mm - 1.1 kW

The powerful SMP25 (3PH) peeler has a high output, making it ideal for medium and large operations with three-phase power.

- ✓ Able to peel 25kg of potatoes in 2 minutes - up to 513kg per hour
- ✓ Hinged locking lid with viewing glass allows peeling progress to monitored
- ✓ Timer and start-stop button located near discharge chute for simple operation
- ✓ Supplied on a stand with an integral filter basket
- ✓ Upright design, ideal for medium and large operations
- ✓ Lubricated, heavy-duty gearbox makes peeling operation smooth and reliable
- ✓ Stainless steel design, for easy cleaning
- ✓ Equipped with easy-to-replace cylinder liners and starch foam reduction system

Specifications

Summary		Power and Performance	
Brand	IMC	Total Power kW	1.1
Range	SMP Peeler	HP	1.47
Power Type	Electric	IP Rating	IP55
Unit Type	Floor-mounted		
Available in UK Only	No		
UK Warranty	2 Years Parts and Labour Warranty		
Export Warranty	Contact your local dealer		
Mounting	Floor-mounted		
GTIN	5056105198765		

Key Specifications		Capacity	
Operator Safety	Interlocks	Capacity Kg per Hour	513
Timer	Yes		
Drain Location	Right or left		
WRAS Approved	WRAS Compliant		
Airbreak	Yes		

Weights and Dimensions		Supply Connections	
Unit Height (External) mm	1293	Requires Installation	Yes
Unit Width (External) mm	608	Requires Electrical Supply	Yes
Unit Depth (External) mm	784	UK 3 Pin Plug	No
Net Weight Kg	82	Requires Hardwiring	Yes
		Motor Rating Watts	1100
		Three Phase Amps	1.1
		Three Phase Voltage	400
		Water Connection Pressure Bar	2.7-3.8 [40-55 psi]
		Drain Connection	38mm
		Water Connection	12mm

Shipping	
Packed Weight Kg	93
Packed Height cm	150
Packed Width cm	82
Packed Depth cm	88

Available Accessories

S58/062

Inlet Hose Kit for MF10/MF10L/MF15/MF15L Vegetable Peeler

Technical Picture

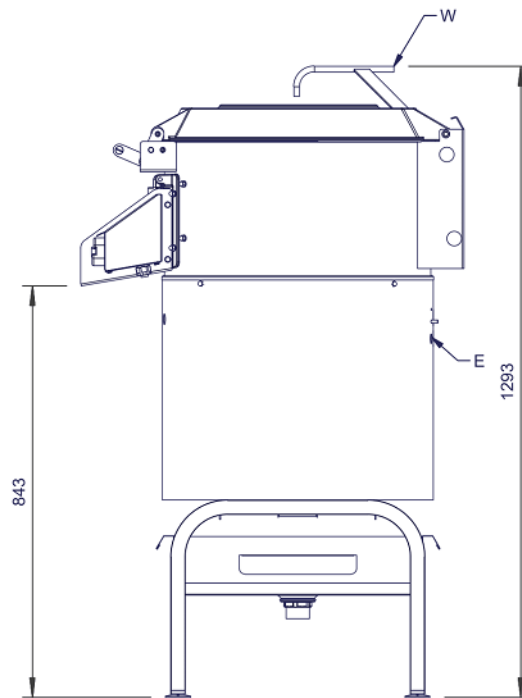
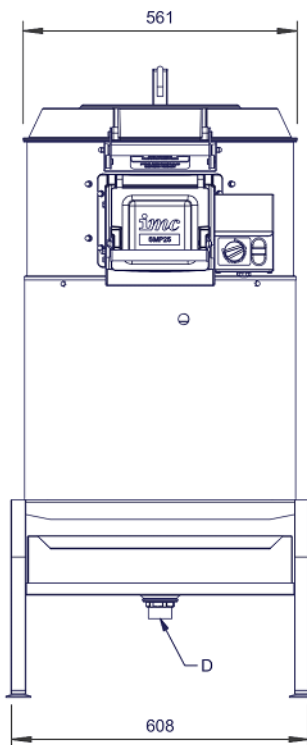
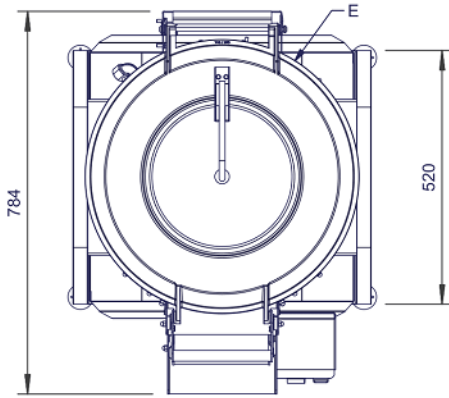



Lincat Limited

Whisby Road,
Lincoln, LN6 3QZ,
United Kingdom

Company No: 2175448

A member company of



Customer Care

Tel: +44 1522 875500
Email: care@lincat.co.uk

Export Customers

Tel: +44 1522 503250
Email: export@lincat.co.uk

Opening Hours

Monday – Friday:
8.30am – 5pm