



## Model

SP-40Hi

## Product Description

Mixer, 40 litre, Heavy Duty

## Product Code

5M220 – Single Phase

5M231 – Three Phase



## Standard Features

- Heavy duty floor standing, gear driven planetary mixer with a powerful 3-speed transmission
- Bowl capacity of 40ltr, bowl trolley available as optional accessory
- Fully integrated 15min timer
- Fully CE approved with an electrically interlocked bowl guard and bowl lift
- Particularly suitable for bakeries, hotels, restaurants, canteens etc
- Available in single and three phases
- Quiet operation
- Permanently lubricated transmission
- Thermal overload protection (No-volt release)
- Resettable thermal overload
- Abrasion resistant transmission design
- Stainless steel revolving safety guard with ingredient chute
- Heat treated hardened steel alloy gears, 25% thicker than the industry leader
- Front mounted controls for easy access and operation
- Industry standard #12 attachment hub
- Non-slip rubber feet
- High torque transmission for heavy loads
- Emergency Stop
- Needs to be hardwired into isolator
- Optional voltages and frequencies available on request

## Standard Accessories / Attachments

- 1 x Whisk
- 1 x Beater
- 1 x Dough Hook
- 1 x 40 litre bowl

## Warranty

Covered by Metcalfe 3-year warranty (1<sup>st</sup> year parts and labour, 2<sup>nd</sup> & 3<sup>rd</sup> years parts only) and full after sales service

## Optional Accessories / Attachments

Item	Product Code	Item	Product Code	Item	Product Code
Spare Bowl	SP40B01	Conversion Kit	SP40C02	Veg Prep Attachment (V99S)	SPV01
Beater	SP40B04	Bowl Scraper	SP40S04	Mincer Attachment (VH-12)	SPM01
Whisk	SP40W02	Bowl Trolley	SPT01		
Dough Hook	SP40D01				

Additional extrusion plates and cutting blades are available for both the VH12 & V99S attachments, please refer to their specification sheets for further details.

## Drawings

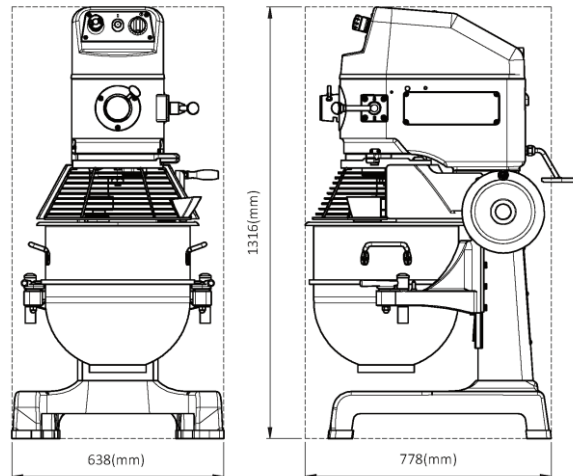

## Specifications

Model	Capacity (ltr)	Phase (Ø)	Motor (Volt)	Frequency (Hz)	Power (kW) / (hp)	Speed (rpm)	Hub (rpm)
SP-40Hi	40	1	230	50	1.2 / 1.5	90, 161 and 291	41, 73 and 133
SP-40Hi	40	3	380	50	1.2 / 1.5	90, 161 and 291	41, 73 and 133

## Dimensions | Shipping Information

Model	Overall Dimensions (D x W x H)	Net Weight (kg)	Packed Dimensions (D x W x H)	Packed Weight (kg)	Volume (m3)
SP-40Hi	738 x 638 x 1316	260	810 x 710 x 1480	280	0.85

We reserve the right to alter the specification and technical details for this item at anytime without prior notice.

©Metcalfe Catering Equipment Ltd

<p>Metcalfe Catering Equipment Ltd Haygarth Park Blaenau Ffestiniog Gwynedd LL41 3PF</p> <p>Tel: 01766 830 456   Fax: 01766 831 170 E-mail: sales@metcalfecatering.com</p>	<p>SP40Hi - 01/2020</p>	<p>View our current catalogue visit: <a href="http://www.metcalfecatering.com/brochure">www.metcalfecatering.com/brochure</a></p> <p>Or scan the QR code</p> 
--	-------------------------	--