

**Model**

SP-60Hi

Product Description

Mixer, 60 litre, Heavy Duty

Product Code

5M230 – Single Phase

5M227 – Three Phase

**Standard Features**

- Heavy duty floor standing, gear driven planetary mixer with a powerful 3-speed transmission
- Bowl capacity of 63 Quarts (60ltr)
- Bowl trolley supplied as standard
- Fully integrated 15min timer
- Fully CE approved with an electrically interlocked bowl guard and bowl lift
- Particularly suitable for bakeries, hotels, restaurants, canteens etc
- Available in single and three phases
- Quiet operation
- Permanently lubricated transmission
- Thermal overload protection (No-volt release)
- Resettable thermal overload
- Abrasion resistant transmission design
- Stainless steel revolving safety guard with ingredient chute
- Heat treated hardened steel alloy gears, 25% thicker than the industry leader
- Front mounted controls for easy access and operation
- Industry standard #12 attachment hub
- Non-slip rubber feet
- High torque transmission for heavy loads
- Emergency Stop
- Needs to be hardwired into isolator
- Optional voltages and frequencies available on request

Standard Accessories / Attachments

- 1 x Whisk
- 1 x Beater
- 1 x Dough Hook
- 1 x 60 litre bowl

Warranty

Covered by Metcalfe 3-year warranty (1st year parts and labour, 2nd & 3rd years parts only) and full after sales service

Optional Accessories / Attachments

Item	Product Code
Spare Bowl	SP60B03
Beater	SP60B01
Whisk	SP60W01
Dough Hook	SP60D01

Item	Product Code
30 Quart Conversion Kit	SP60C08
Bowl Scraper	SP60SCRP
Bowl Trolley	SPT01

Item	Product Code
Veg Prep Attachment (V99S)	SPV01
Mincer Attachment (VH-12)	SPM01

Additional extrusion plates and cutting blades are available for both the VH12 & V99S attachments, please refer to their specification sheets for further details.

Drawings

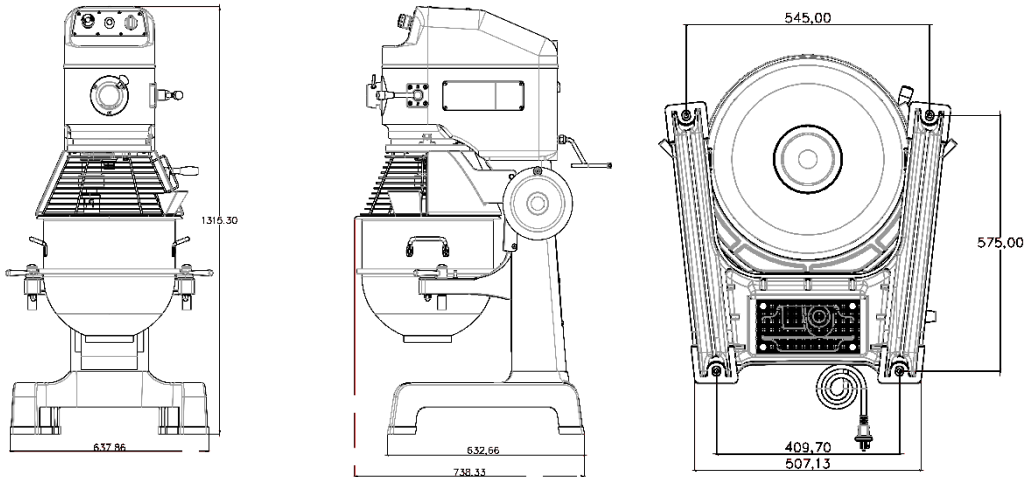

Specifications

Model	Capacity (ltr)	Phase (Ø)	Motor (Volt)	Frequency (Hz)	Power (kW) / (hp)	Speed (rpm)	Hub (rpm)
SP-60Hi	60	1	230	50	1.5 / 3.0	99, 176 and 320	60, 108 and 197
SP-60Hi	60	3	380	50	1.5 / 3.0	99, 176 and 320	69, 108 and 197

Dimensions | Shipping Information

Model	Overall Dimensions (D x W x H)	Net Weight (kg)	Packed Dimensions (D x W x H)	Packed Weight (kg)	Volume (m3)
SP-60Hi	720 x 630 x 1300	285	801 x 695 x 1480	310	0.82

We reserve the right to alter the specification and technical details for this item at anytime without prior notice.

©Metcalfe Catering Equipment Ltd

Metcalfe Catering Equipment Ltd
 Haygarth Park
 Blaenau Ffestiniog
 Gwynedd
 LL41 3PF
 Tel: 01766 830 456 | Fax: 01766 831 170
 E-mail: sales@metcalfecatering.com

View our current catalogue visit:
www.metcalfecatering.com/brochure

Or scan the QR code

