



Model

SP-80

Product Description

Mixer, 8 litre, Heavy Duty

Product Code

5M228

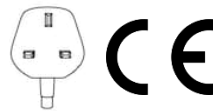

Standard Features

- Durable, counter top gear driven planetary mixer with a powerful 3-speed transmission
- Total bowl capacity of 8 Quarts (7.5ltr)
- Fully integrated timer
- Fully CE approved with an electrically interlocked bowl guard and bowl lift
- Particularly suitable for bakeries, hotels, restaurants, canteens etc
- Easy to operate
- Overload protection (No-volt Release)
- Heat treated hardened steel alloy gears, 25% thicker than the industry leader
- Abrasion resistant transmission design
- Efficient, custom made, powerful motor
- High torque transmission for heavy loads
- Long lasting lubricant
- Quiet operation
- Emergency Stop
- 15-minute timer
- Resettable thermal overload
- Plastic safety guard with ingredient chute

Standard Accessories / Attachments

- 1 x Whisk
- 1 x Beater
- 1 x Dough Hook
- 1 x 8 litre bowl

Warranty

Covered by Metcalfe 3-year warranty (1st year parts and labour, 2nd & 3rd years parts only) and full after sales service.

Optional Accessories / Attachments

Item	Product Code
Spare Bowl	SP80B01
Beater	SP80B02

Item	Product Code
Whisk	SP80W01
Dough Hook	SP80D01

Drawings

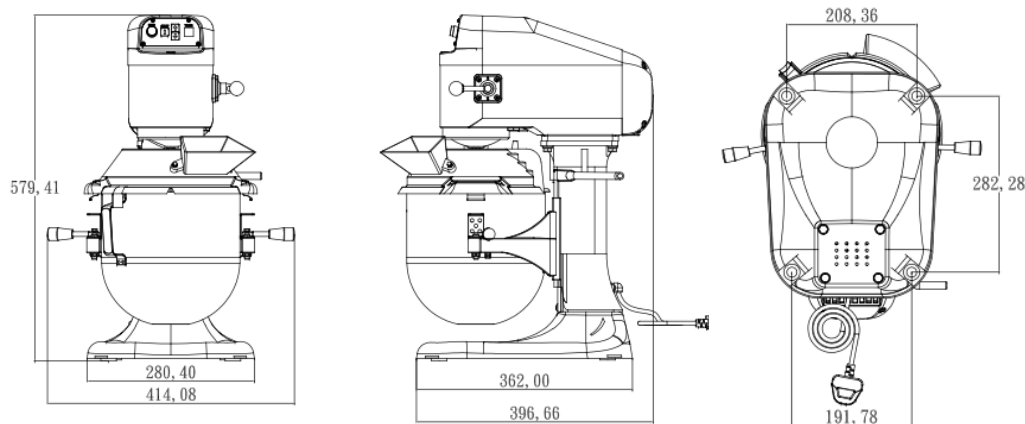

Specifications

Model	Capacity (ltr)	Phase (Ø)	Motor (Volt)	Frequency (Hz)	Power (kW) / (hp)	Speed (rpm)
SP-80	7.5	1	230	50	0.2 / 0.25	132, 235 and 260

Dimensions | Shipping Information

Model	Overall Dimensions (D x W x H)	Net Weight (kg)	Packed Dimensions (D x W x H)	Packed Weight (kg)	Volume (m3)
SP-80	397 x 414 x 580	25.5	490 x 470 x 635	27.75	0.11

<p>Metcalfe Catering Equipment Ltd Haygarth Park Blaenau Ffestiniog Gwynedd LL41 3PF Tel: 01766 830 456 Fax: 01766 831 170 E-mail: sales@metcalfecatering.com</p>		<p>View our current catalogue visit: www.metcalfecatering.com/brochure</p> <p>Or scan the QR code</p> 
---	--	---