

Automatic Washers

Metered and Nonmetered

Installation/Operation

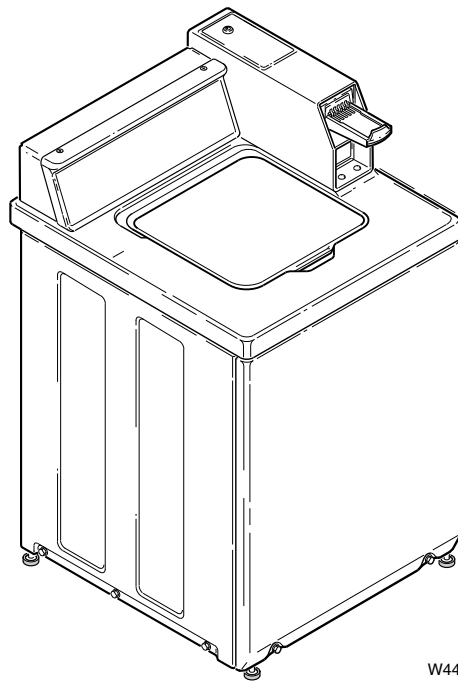

W4461

Para bajar una copia de estas instrucciones en español, visite www.comlaundry.com.

Keep These Instructions for Future Reference.

(If this machine changes ownership, this manual must accompany machine.)



www.comlaundry.com

Part No. 201932R5
August 2012



WARNING

For your safety and to reduce the risk of fire or an explosion, do not store or use gasoline or other flammable vapors and liquids in the vicinity of this or any other appliance.

W022

**IMPORTANT: Read the complete
INSTALLATION/OPERATION INSTRUCTIONS
before using the washer.**

Table of Contents

Safety Information	4
Explanation of Safety Messages.....	4
Important Safety Instructions	4
Installation	6
Dimensions and Specifications.....	6
Before You Start.....	7
Tools	7
Installing the Washer	7
Step 1: Remove the Shipping Brace and Shipping Plug.....	7
Step 2: Wipe Out Inside of Washtub	8
Step 3: Connect Fill Hoses.....	8
Step 4: Connect Drain Hose to Drain Receptacle.....	10
Step 5: Position and Level the Washer	11
Step 6: Plug In the Washer.....	12
Step 7: Add Water to the Washer	13
Step 8: Check Lid Switch	13
Step 9: Check Installation	13
Vending.....	14
Meter Case	14
Slide Extension Assembly – Models through Serial No. 1211.....	14
Slide Extension Assembly – Models Starting Serial No. 1211	15
Models Prepped for Card Reader.....	17
Additional Washer Security	18
Operation	19
Operation Instructions for Coin Slide Operated and Nonmetered Washers	19
Step 1: Add Detergent.....	19
Step 2: Load Laundry.....	19
Step 3: Close Lid.....	19
Step 4: Set Wash Temperature and Fabric/Cycle Selector	20
Step 5: Start Washer.....	21
Indicator Lights	21
Control Modes	22
Rapid Advance.....	23
Setting Dipswitch.....	23
Operation Instructions for Electronic Display Control Washers.....	24
Step 1: Add Detergent.....	24
Step 2: Load Laundry.....	24
Step 3: Close Lid.....	24
Step 4: Choose Small Load, if Desired	25
Step 5: Set Fabric Selector	25
Step 6: Set Wash Temperature.....	25
Step 7: Insert Money	25
Indicator Lights	26

© Copyright 2012, Alliance Laundry Systems LLC

All rights reserved. No part of the contents of this book may be reproduced or transmitted in any form or by any means without the expressed written consent of the publisher.

Operation Instructions for MDC Washers.....	27
Step 1: Add Detergent.....	27
Step 2: Load Laundry.....	27
Step 3: Close Lid.....	27
Step 4: Choose Small Load, if Desired.....	28
Step 5: Set Fabric Selector and Wash Temperature.....	28
Step 6: Insert Money or Card.....	28
Step 7: Start Washer.....	29
Indicator Lights.....	29
Operation Instructions for NetMaster Washers.....	30
Step 1: Add Detergent.....	30
Step 2: Load Laundry.....	30
Step 3: Close Lid.....	30
Step 4: Choose Small Load, if Desired.....	31
Step 5: Set Fabric Selector.....	31
Step 6: Set Wash Temperature.....	31
Step 7: Insert Money or Card.....	32
Step 8: Start Washer.....	32
Indicator Lights.....	32
Maintenance	33
User-Maintenance Instructions.....	33
Cold Weather Care.....	33
Care of Your Washer.....	33
Replacing Hoses.....	33
Filter Screens.....	33
Reinstallation of Shipping Materials.....	33
Motor Overload Protector.....	33
Troubleshooting	34
Contact Information	36
Installer Checklist	Back Cover

Safety Information

Explanation of Safety Messages

Throughout this manual and on machine decals, you will find precautionary statements (“DANGER,” “WARNING,” and “CAUTION”) followed by specific instructions. These precautions are intended for the personal safety of the operator, user, servicer, and those maintaining the machine.

	DANGER
Indicates an imminently hazardous situation that, if not avoided, will cause severe personal injury or death.	

	WARNING
Indicates a hazardous situation that, if not avoided, could cause severe personal injury or death.	

	CAUTION
Indicates a hazardous situation that, if not avoided, may cause minor or moderate personal injury or property damage.	

Additional precautionary statements (“IMPORTANT” and “NOTE”) are followed by specific instructions.

IMPORTANT: The word “IMPORTANT” is used to inform the reader of specific procedures where minor machine damage will occur if the procedure is not followed.

NOTE: The word “NOTE” is used to communicate installation, operation, maintenance or servicing information that is important but not hazard related.

Important Safety Instructions

Save These Instructions

	WARNING
To reduce the risk of fire, electric shock, serious injury or death to persons when using your washer, follow these basic precautions:	
W023	

1. Read all instructions before using the washer.
2. Install the washer according to the **INSTALLATION INSTRUCTIONS**. Refer to the **EARTHING (GROUNDING) INSTRUCTIONS** in the **INSTALLATION** manual for the proper earthing (grounding) of the washer. All connections for water, drain, electrical power and earthing (grounding) must comply with local codes and be made by licensed personnel when required. Do not do it yourself unless you know how!
3. Do not install or store the washer where it will be exposed to water and/or weather.
4. Do not add the following substances or textiles containing traces of the following substances to the wash water: gasoline, kerosene, waxes, cooking oils, vegetable oils, machine oils, dry-cleaning solvents, flammable chemicals, thinners or other flammable or explosive substances. These substances give off vapors that could ignite, explode or cause the fabric to catch on fire by itself.
5. Under certain conditions, hydrogen gas may be produced in a hot water system that has not been used for two weeks or more. **HYDROGEN GAS IS EXPLOSIVE**. If the hot water system has not been used for such a period, before using a washing machine or combination washer-dryer, turn on all hot water faucets and let the water flow from each for several minutes. This will release any accumulated hydrogen gas. **THE GAS IS FLAMMABLE, DO NOT SMOKE OR USE AN OPEN FLAME DURING THIS TIME**.
6. To reduce the risk of an electric shock or fire, **DO NOT** use an extension cord or an adapter to connect the washer to the electrical power source.

7. Do not allow children to play on or in the washer. Close supervision of children is necessary when the washer is used near children. This appliance is not intended for use by persons (including children) with reduced physical, sensory or mental capabilities, or lack of experience and knowledge, unless they have been given supervision or instruction concerning the use of the appliance by a person responsible for their safety. This is a safety rule for all appliances.
8. Do not reach into the washer if the washtub or agitator is moving.
9. Never operate the washer with any guards , panels and/or parts removed or broken. DO NOT tamper with the controls or bypass any safety devices.
10. DO NOT operate individual units if they have been separated from a stack unit.
11. Use your washer only for its intended purpose, washing clothes. Always follow the fabric care instructions supplied by the garment manufacturer.
12. Always read and follow manufacturer's instructions on packages of laundry and cleaning aids. To reduce the risk of poisoning or chemical burns, keep them out of the reach of children at all times (preferably in a locked cabinet). Heed all warnings or precautions.
13. Do not use fabric softeners or products to eliminate static unless recommended by the manufacturer of the fabric softener or product.
14. Lid MUST BE CLOSED any time the washer is to agitate or spin. DO NOT bypass the lid switch by permitting the washer to agitate or spin with the lid open. A brake will stop the washtub within seconds if the lid is opened during spinning. If the washtub does not stop when the lid is opened, remove the washer from use and call the service person.
15. Be sure water connections have a shut-off valve and that fill hose connections are tight. CLOSE the shut-off valves at the end of each wash day.
16. Keep your washer in good condition. Bumping or dropping the washer can damage safety features. If this occurs, have your washer checked by a qualified service person.
17. Do not repair or replace any part of the washer, or attempt any servicing unless specifically recommended in the user-maintenance instructions or in published user-repair instructions that you understand and have the skills to carry out. ALWAYS disconnect the washer from electrical supply before attempting any service.
18. Disconnect the power cord by grasping the plug, not the cord. If the supply cord is damaged, it must be replaced by a special cord or assembly available from the manufacturer or its service agent.
19. Before the washer is removed from service or discarded, remove the lid to the washing compartment.
20. Failure to install, maintain, and/or operate this washer according to the manufacturer's instructions may result in conditions which can produce bodily injury and/or property damage.

NOTE: The WARNING and IMPORTANT SAFETY INSTRUCTIONS appearing in this manual are not meant to cover all possible conditions and situations that may occur. Common sense, caution and care must be exercised when installing, maintaining, or operating the washer.

Always contact your dealer, distributor, service agent or the manufacturer about any problems or conditions you do not understand.

Installation

Dimensions and Specifications

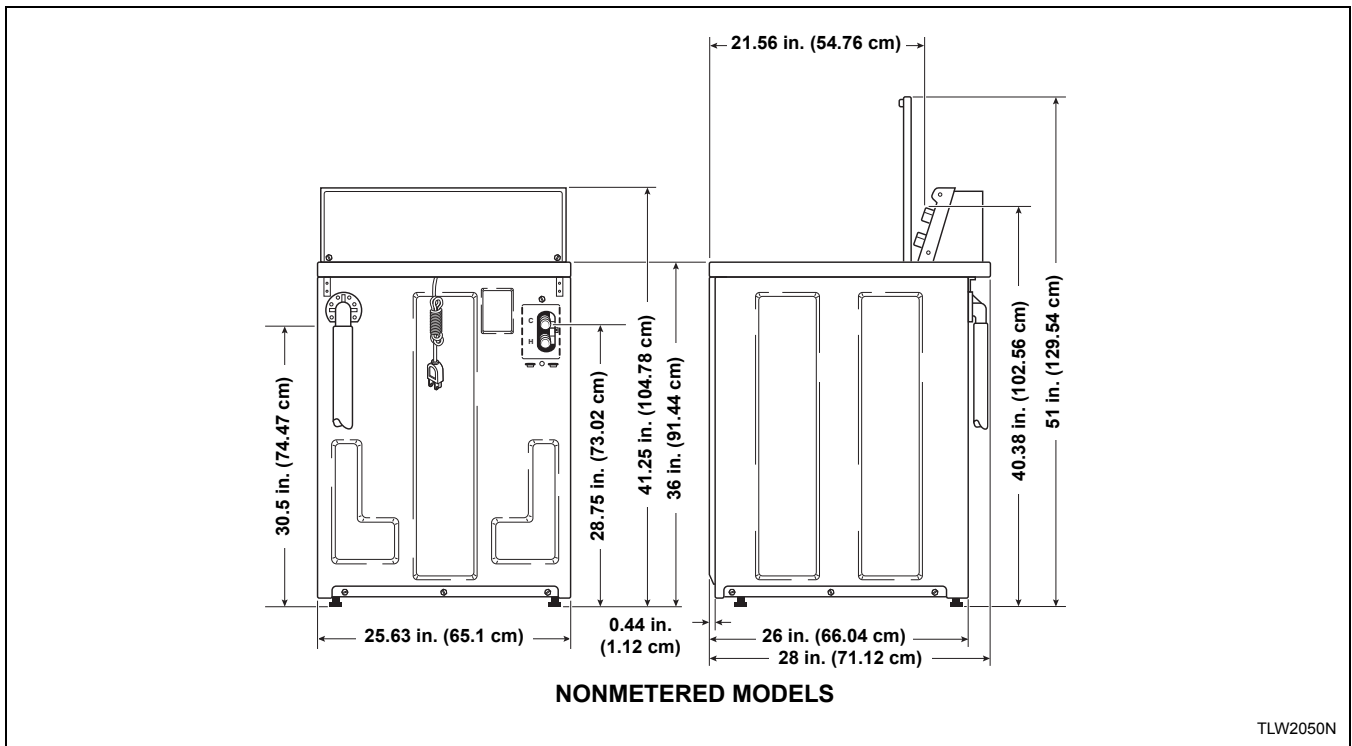
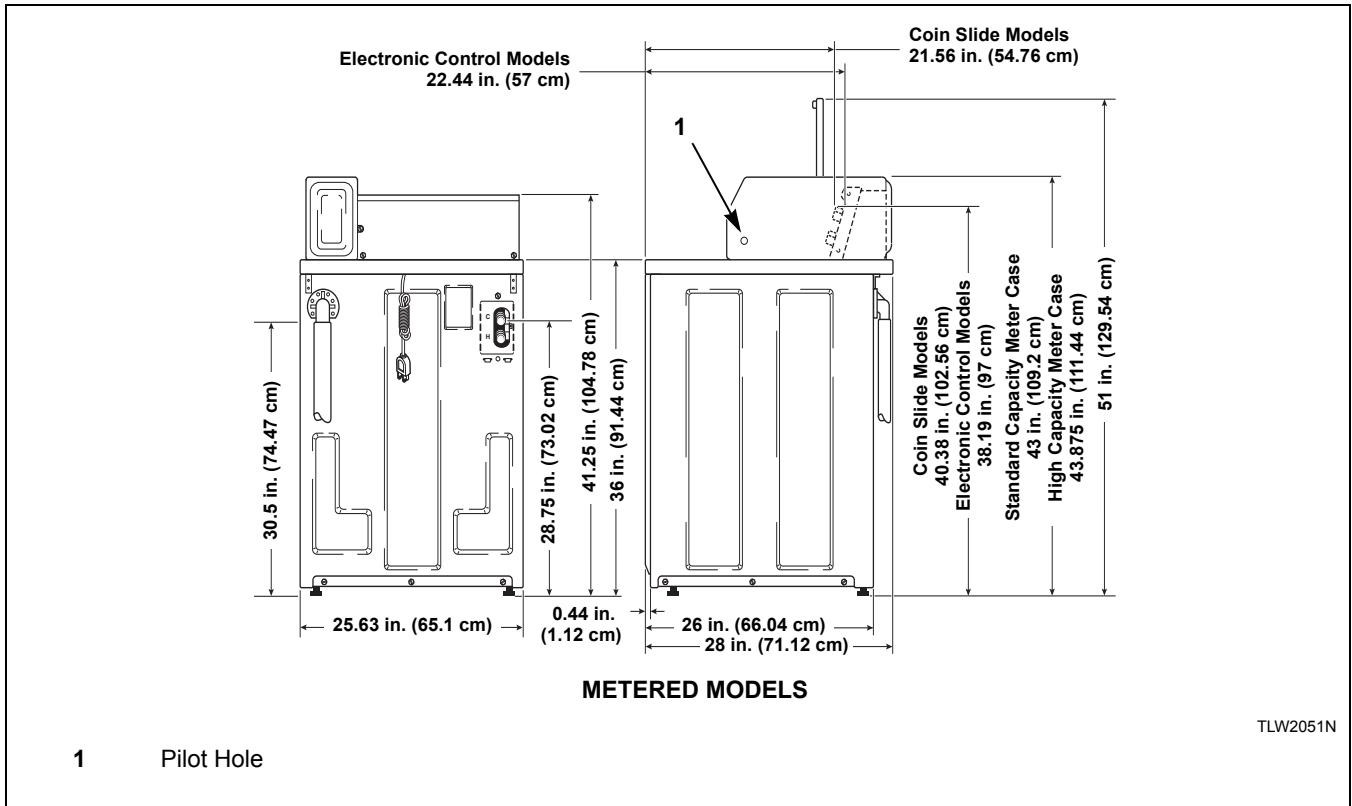

Before You Start

Tools

For most installations, the basic tools you will need are:

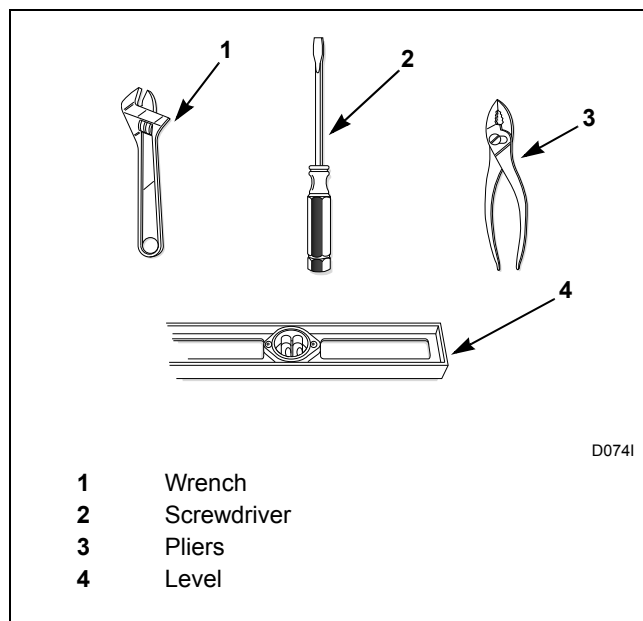

Figure 1

NOTE: If the washer is delivered on a cold day (below freezing), or is stored in an unheated room or area during the cold months, do not attempt to operate it until the washer has had a chance to warm up.

IMPORTANT: Install dryer before washer. This allows room for attaching exhaust duct.

Installing the Washer

Step 1: Remove the Shipping Brace and Shipping Plug

Remove the shipping brace from under the lid.

The shipping plug will be released from the base of the washer when removing the cardboard base from the washer. Refer to *Figure 2*.

The shipping brace and plug should be saved and must be reinstalled whenever washer is moved or transported to a new location. This will prevent damage to washer components.

Do not tilt washer to front or sides when moving.

Refer to *User-Maintenance* section for instructions on reinstalling shipping brace and shipping plug.

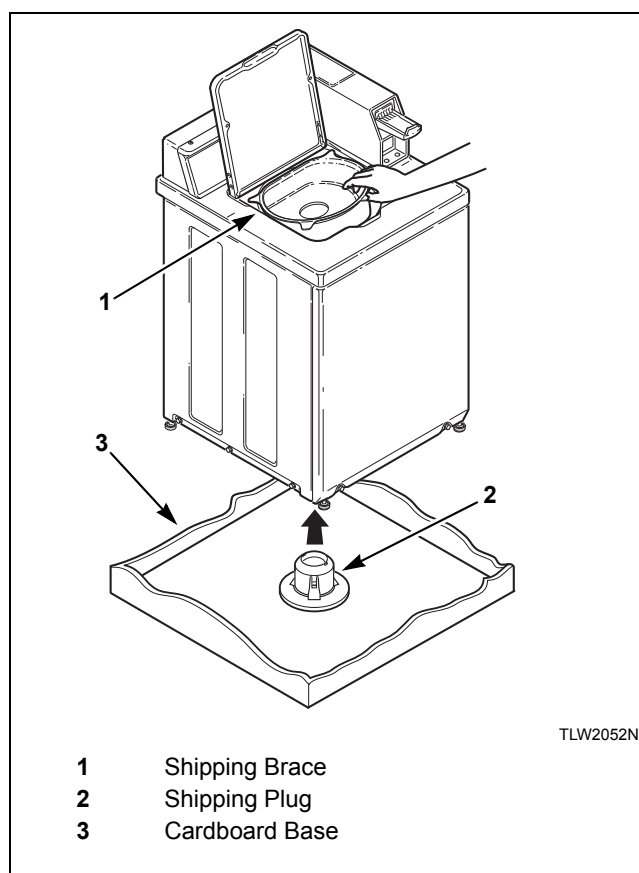

Figure 2

Installation

Step 2: Wipe Out Inside of Washtub

Prior to first wash, use an all purpose cleaner or a detergent and water solution and a damp cloth to remove shipping dust from inside of washtub.

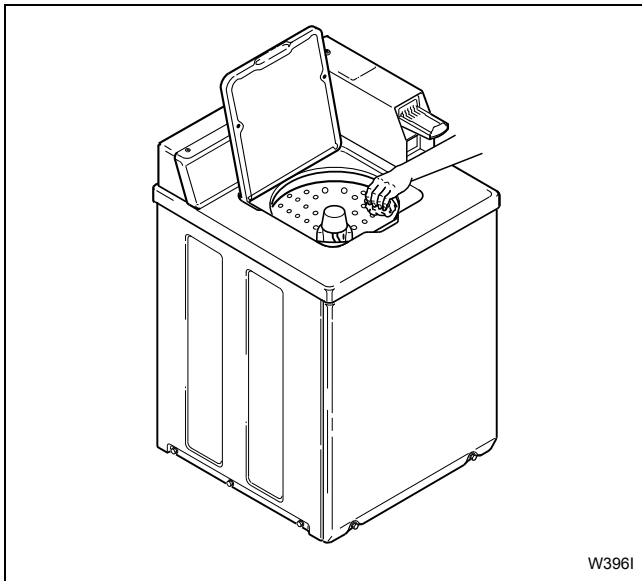

Figure 3

Water Supply Requirements

Water supply faucets must fit standard 3/4 inch (19.1 mm) female garden hose couplings. **DO NOT USE SLIP-ON OR CLAMP-ON CONNECTIONS.**

NOTE: Water supply faucets should be readily accessible to permit turning them off when washer is not being used.

Recommended cold water temperature is 50° to 75° Fahrenheit (10° to 24° Celsius). Recommended maximum hot water temperature is 125° Fahrenheit (51° Celsius). Warm water is a mixture of hot and cold water. Warm water temperature is dependent upon the water temperature and the pressure of both the hot and cold water supply lines.

	WARNING
<p>To prevent personal injury, avoid contact with inlet water temperatures higher than 125° Fahrenheit (51° Celsius) and hot surfaces.</p>	
W748	

Step 3: Connect Fill Hoses

	WARNING
<p>Under certain conditions, hydrogen gas may be produced in a hot water system that has not been used for two weeks or more. HYDROGEN GAS IS EXPLOSIVE. If the hot water system has not been used for such a period and before using the washer, turn on all hot water faucets and let the water flow from each for several minutes. This will release any accumulated hydrogen gas. The gas is flammable. Do not smoke or use an open flame during this time.</p>	
W029	

Pressure must be a minimum of 20 to a maximum of 120 pounds per square inch (138 to 827 kPa) static pressure measured at the faucet.

NOTE: Water pressure under 20 pounds per square inch (138 kPa) will cause an extended fill time in the washer.

Turn on the water supply faucets and flush the lines for approximately two minutes to remove any foreign materials that could clog the screens in the water mixing valve. (This is especially important when installing your washer in a newly constructed or renovated building.)

Mixing Valve Flow Rates			
Pressure (psi)	HOT gallons per minute (liters per minute)	COLD gallons per minute (liters per minute)	WARM gallons per minute (liters per minute)
35	2.4 (9.1)	4.5 (17.0)	7.15 (27.1)
55	3.5 (13.2)	6.2 (23.5)	9.2 (34.8)

Table 1

Connecting Hoses

Insert rubber washers and filter screens (from accessories bag) in water fill hose couplings (two hoses supplied with washer). Connect fill hoses to water supply faucets. Then connect the hoses to the hot and cold valve connections at the rear of the washer. Refer to *Figure 4*. Thread hose couplings onto valve connections finger tight. Then turn 1/4 turn with pliers.

IMPORTANT: DO NOT cross thread or overtighten couplings.

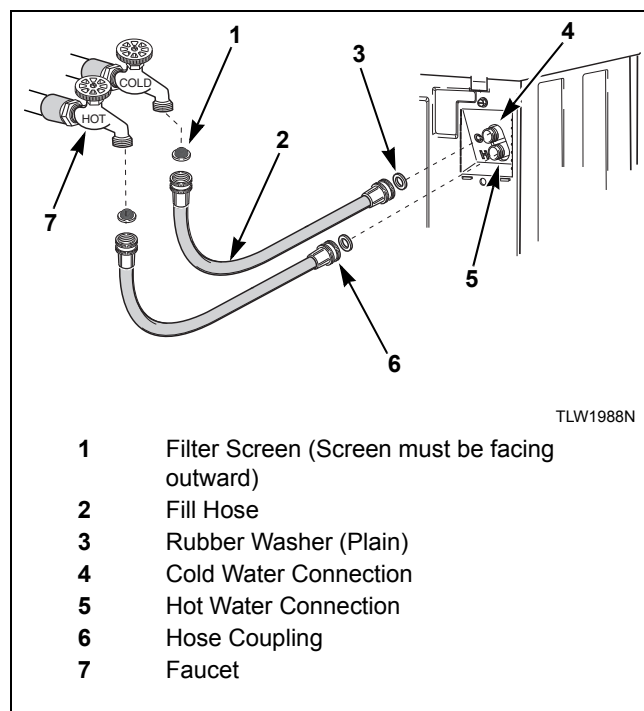

Figure 4

IMPORTANT: Hoses and other natural rubber parts deteriorate after extended use. Hoses may develop cracks, blisters or material wear from the temperature and constant high pressure they are subjected to.

All hoses should be checked on a monthly basis for any visible signs of deterioration. Any hose showing the signs of deterioration listed above should be replaced immediately. All hoses should be replaced every five years.

IMPORTANT: Turn off water supply faucets after check-out and demonstration. Owner should turn off water supply whenever there will be an extended period of non-use.

NOTE: Longer fill hoses are available (as optional equipment at extra cost) if the hoses (supplied with the washer) are not long enough for the installation. Order hoses as follows:

- No. 20617 Fill Hose (8 feet) (2.44 m)
- No. 20618 Fill Hose (10 feet) (3.05 m)

Risers

Risers (or air cushions) may have to be installed if the pipes knock or pound when flow of water stops. The risers are more efficient when installed as close as possible to the water supply faucets. Refer to *Figure 5*.

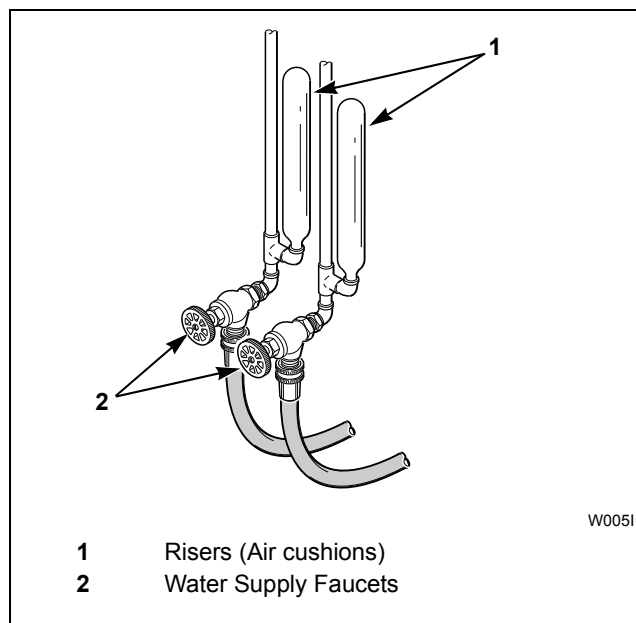

Figure 5

Installation

Step 4: Connect Drain Hose to Drain Receptacle

Drain Facilities

IMPORTANT: The drain hose installation is a very important factor in the washer installation. If care is not taken when the drain hose is installed, a siphoning action can be started which will cause water to be siphoned from the washer during the cycle.

End of drain hose should never be in water as siphoning action can be started that will cause water to be siphoned back into the washer.

The curved end of drain hose **MUST** be installed even with or above the height of the cabinet top of the washer to prevent siphoning. Refer to *Figure 6*.

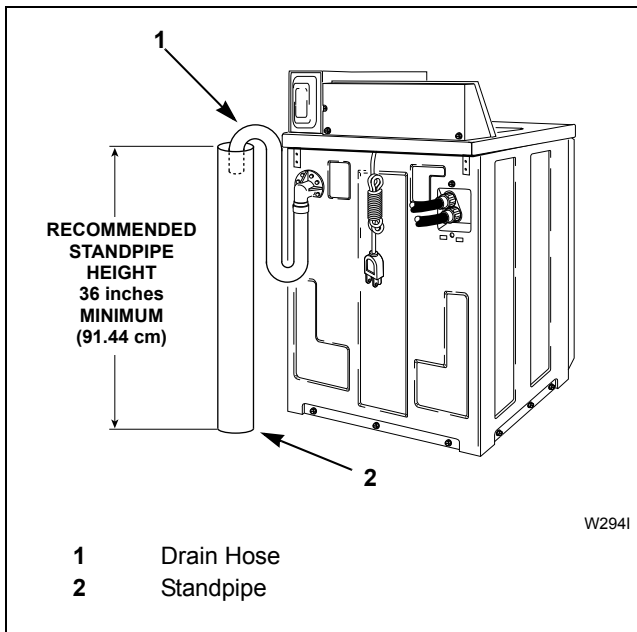

Figure 6

The standpipe or drain receptacle must be capable of handling a minimum of 1-1/2 inches (3.8 cm) outside diameter drain hose. The drain hose should fit loose within the standpipe (it should not be snug fit). Never install the drain hose into a “sealed” drain system as air cannot escape and will restrict the water from being drained from the washer. A sealed drain system may also allow water to be pumped back into the washer during agitation. Both of these conditions may result in flooding of the washer.

Remove the drain hose from its shipping position on the rear of the washer by unhooking the hose from the retainer clamp.

If necessary, follow the instructions for your type of drain receptacle (high standpipe or low standpipe) to properly install the drain hose.

High Standpipe Installation

NOTE: No. 562P3 Siphon Break Kit and No. 25863 Hose Coupling are not required for this type of installation.

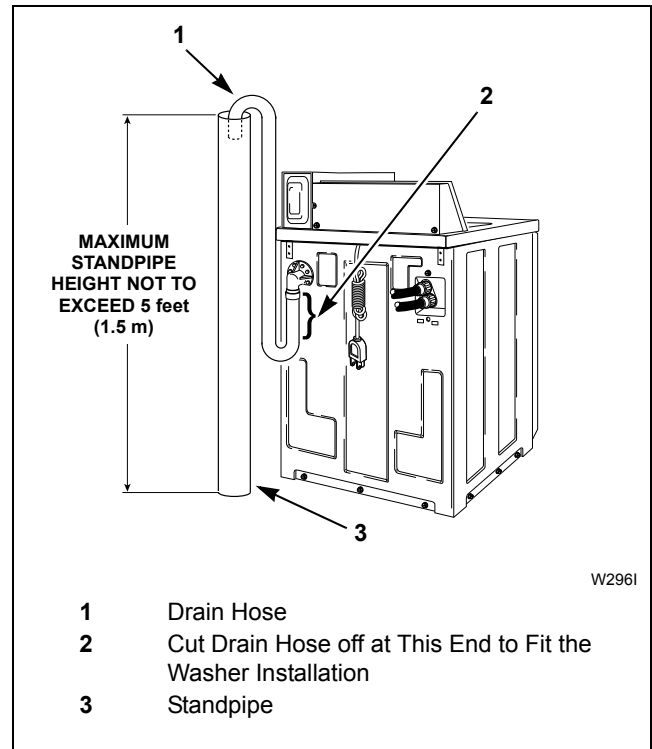

Figure 7

IMPORTANT: Drain receptacle must be capable of handling a minimum of 1-1/2 inch (3.8 cm) outside diameter drain hose.

Low Standpipe Installation

If the drain facility is lower than the cabinet top, a siphon break kit, Part No. 562P3, must be installed in the drain hose to prevent siphoning action and drain hose **MUST** be cut to fit the washer installation. Refer to *Figure 8*. Use one No. 25863 Hose Coupling to splice hose. The No. 562P3 Siphon Break Kit and No. 25863 Hose Coupling are available as optional equipment at extra cost through an authorized dealer or parts distributor. Installation instructions are supplied with the kit.

OPTIONAL: Raise the standpipe to the recommended height of 36 inches (91.44 cm).

IMPORTANT: Drain receptacle must be capable of handling a minimum of 1-1/2 inch (3.8 cm) outside diameter drain hose.

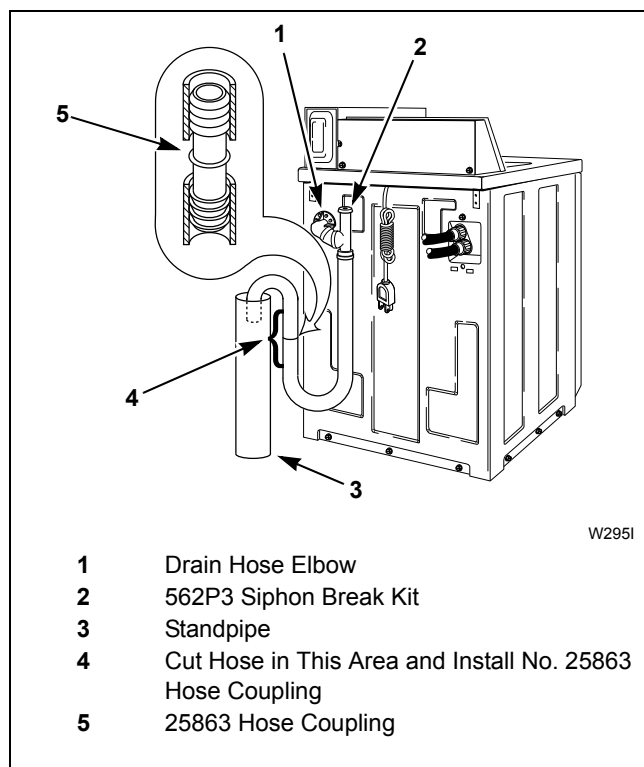

Figure 8

Step 5: Position and Level the Washer

Position washer so it has sufficient clearance for installation and servicing.

Place washer in position on a clean, dry, and reasonably firm floor. Installing the washer on any type of carpeting is not recommended.

Place rubber cups on all four leveling legs.

Place a level on the cabinet top and check if the washer is level from side to side and front to back.

If washer is not level, tilt washer back to access the front leveling legs. Loosen the locknuts and adjust legs by screwing into or out of washer base.

Once adjusted, tilt the washer forward on front legs and lower back down into position to set the rear self-leveling legs.

Washer must not rock. After washer is at desired height, tighten locknuts securely against bottom of washer base. If these locknuts are not tight, washer will not remain stationary during operation.

Improper installation or flexing of weak floor will cause excessive vibration.

Do not slide washer across floor once the leveling legs have been extended, as legs and base could become damaged.

NOTE: For areas with uneven floors, a No. 566P3 Adjustable Rear Leg Extension Kit is available as optional equipment at extra cost.

Verify that unit does not rock.

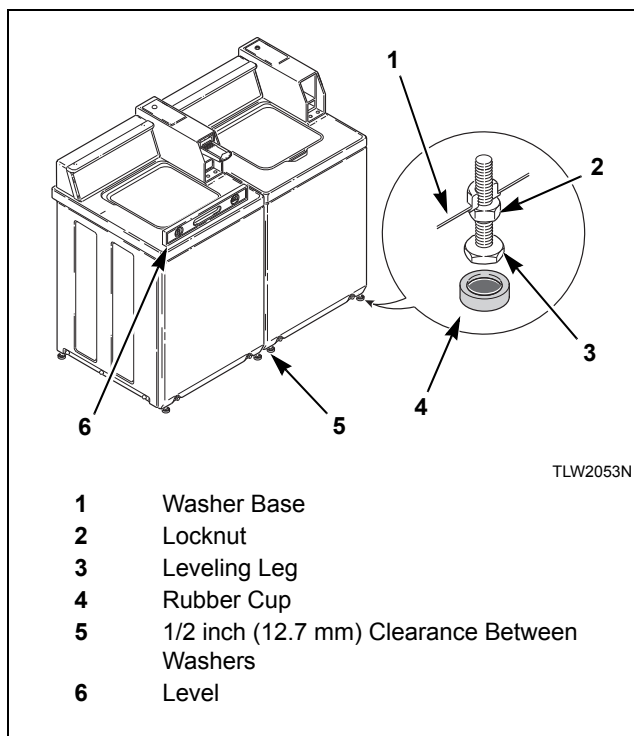

Figure 9

Installation

Step 6: Plug In the Washer

Electrical Requirements

(120 Volt, 60 Hertz with 3-Prong Grounding Plug)

NOTE: The wiring diagram is located in the control hood.

	WARNING
<p>To reduce the risk of fire, electric shock, serious injury or death, all wiring and grounding MUST conform with the latest edition of the National Electrical Code, ANSI/NFPA No. 70, and such local regulations as might apply. It is the customer's responsibility to have the wiring, fuses and circuit breakers installed by a qualified electrician to make sure adequate electrical power is available to the washer.</p>	
W518	

When plugging in the washer:

- DO NOT overload circuits.
- DO NOT use an extension cord.
- DO NOT use an adapter.
- DO NOT operate other appliances on the same circuit. Use separately fused 15 Amp circuits.

The washer is designed to be operated on a separate branch, polarized, three-wire, effectively grounded, 120 Volt, 60 Hertz, AC (alternating current), circuit protected by a **15 ampere fuse**, equivalent fusetrone or circuit breaker.

The three-prong grounding plug on the power cord should be plugged directly into a polarized three-slot effectively grounded receptacle rated 110/120 Volts AC (alternating current) 15 Amps. Refer to *Figure 10* to determine correct polarity of the wall receptacle.

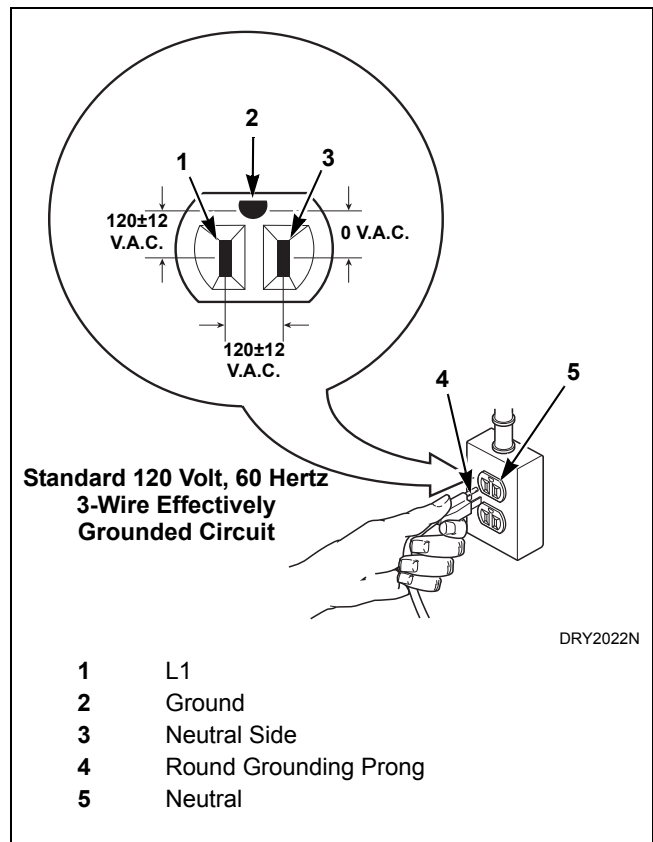



Figure 10

	WARNING
<p>To reduce the risk of an electric shock or fire, DO NOT use an extension cord or an adapter to connect the washer to the electric power source.</p>	
W082	

Grounding Instructions

The washer must be grounded. In the event of malfunction or breakdown, grounding will reduce the risk of electric shock by providing a path of least resistance for electric current.

The washer is equipped with a cord having an equipment-grounding conductor and a three-prong grounding plug. The plug must be plugged into an appropriate outlet that is properly installed and grounded in accordance with all local codes and ordinances.

	WARNING
<p>Improper connection of the equipment-grounding conductor can result in a risk of electric shock. Check with a qualified electrician or service person if you are in doubt as to whether the washer is properly grounded.</p>	
W327	

- **DO NOT** modify the plug provided with the washer – if it will not fit the outlet, have a proper outlet installed by a qualified electrician.
- If the laundry room’s electrical supply does not meet the above specifications and/or if you are not sure the laundry room has an effective ground, have a qualified electrician or your local electrical utility company check it and correct any problems.

	WARNING
<p>Any disassembly requiring the use of tools must be performed by a suitably qualified service person.</p>	
W299	

Step 7: Add Water to the Washer

To prevent damage to pump, do not run washer before adding at least one quart water to the tub. If the washer is run before any water is added, the pump seal may overheat, causing the pump to leak. Once installed, the water retained in the drain system from the previous cycle will provide sufficient cooling to prevent pump seal damage.

NOTE: The agitator should not be removed except for service. The washtub is designed to be self-cleaning.

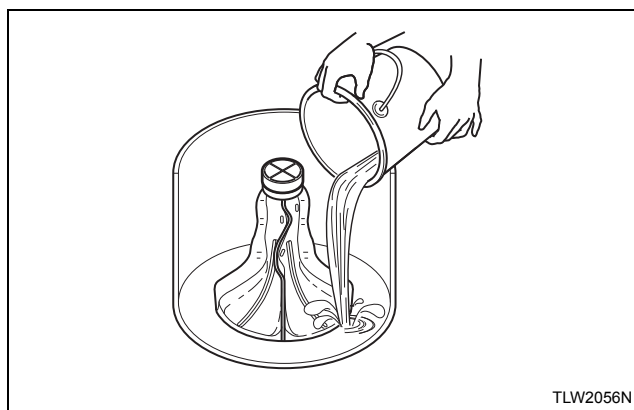

Figure 11

Step 8: Check Lid Switch

Washer should stop filling, agitating and spinning when lid is opened.

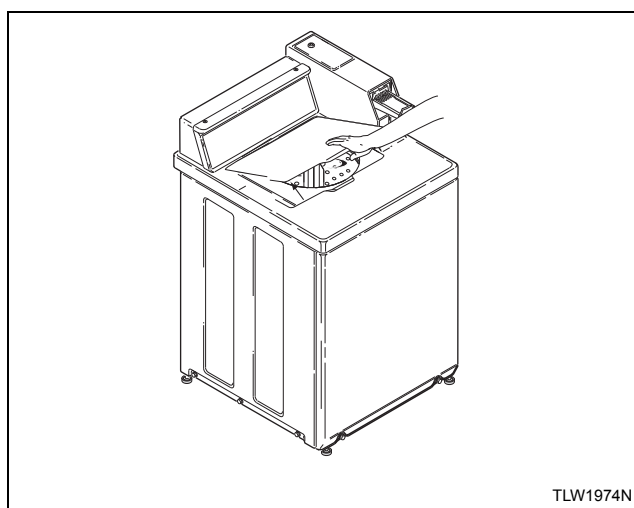

Figure 12

Step 9: Check Installation

Refer to *Installer Checklist* on the back cover of this manual and make sure that washer is installed correctly.

Run washer through one complete cycle to make sure it is operating properly.

Installation

Vending

Meter Case

The factory mounted coin meter case does not include the service door lock, coin slide, coin drawer, coin drawer lock or keys. These parts must be ordered (at extra cost) according to the purchaser's requirements direct from the manufacturer of your choice.

NOTE: On models with standard capacity meter case and high capacity meter case models starting with Serial Nos. beginning 1010, you have the option of using a screw type lock or a 1/4 turn lock on the meter case service door. If you choose to use a screw lock, then the special bracket (located inside the meter case) must be used. DO NOT use the special bracket if a 1/4 turn lock is used. High capacity meter case models with Serial Nos. beginning 0910 through 1010 use 1/4 turn lock only.

Coin Drawer Security (Models with Standard Capacity Meter Case and High Capacity Meter Case models starting with Serial Nos. beginning 1010 Only) – For additional security, drill out the two pilot holes on each side of the front of the meter case to 1/4 or 5/16 inch (6.4 or 7.9 mm) holes and install a bicycle lock through these holes.

NOTE: An 8 in. (20.32 cm) coin drawer is required for coin operated electronic control models with standard capacity meter case and high capacity meter case models starting with Serial Nos. beginning 1010. High capacity meter case models with Serial Nos. beginning 0910 through 1010 require a 7.21 in. (18.31 cm) coin drawer.

Slide Extension Assembly – Models through Serial No. 1211

(Coin Slide Models with Standard Capacity Meter Case and High Capacity Meter Case models starting with Serial Nos. beginning 1010 Only)

NOTE: High capacity meter case models with Serial Nos. beginning 0910 through 1010 require a coin slide with a switch installed on it.

1. Remove slide extension parts from parts accessories bag included in unit.

2. If installing a Greenwald coin slide, position extension lever (to be installed on extension bracket) with arm that has one star facing down. Refer to *Figure 13*.

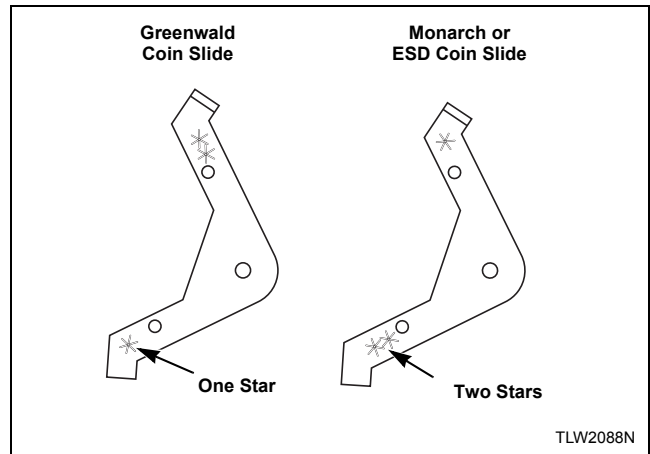

Figure 13

3. If installing a Monarch or ESD coin slide, position lever with arm that has two stars facing down. Refer to *Figure 13*.
4. Install extension lever with rounded corner facing away from extension bracket using bolt, one or two flat washers (shims) (use number of washers included in kit) and nut. Refer to *Figure 14*. Make sure washers are flat against bracket.

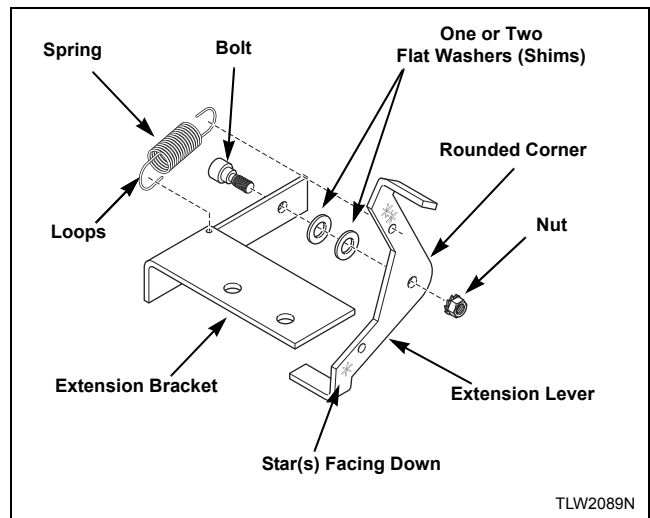

Figure 14

5. Torque nut between 2 and 2.26 Nm (18 and 20 inch-pounds), or tighten nut firmly.
6. Install extension spring in bracket hole and hole in upper arm of lever. Refer to *Figure 14*.
7. Bend loops closed after installation.
8. Check to make sure the lever swings freely.

**Installing Extension Onto Coin Slide:
Option 1**

1. Install slide extension onto top of coin slide using two remaining screws and lockwashers. Refer to *Figure 15*.

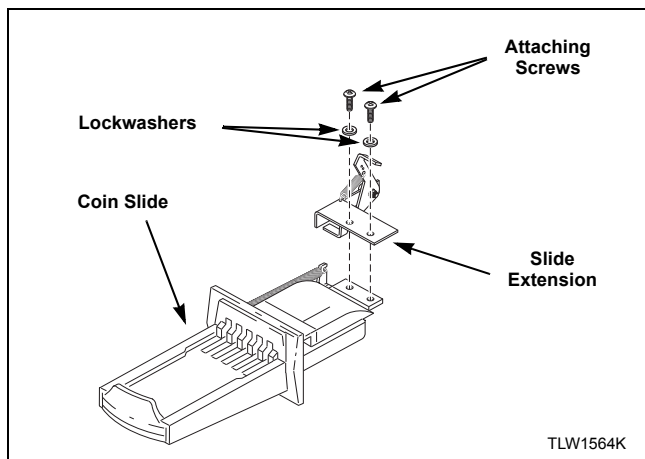

Figure 15

2. Insert coins and partially extend coin slide.
3. Insert coin slide on its side through meter case opening. Then rotate 90 degrees to its proper orientation.
4. Return coin slide and hook slide pins onto meter case.
5. Continue coin slide installation according to manufacturer's instructions.

NOTE: During coin slide installation, make sure activation lever is up and off the switch. Refer to *Figure 16*.

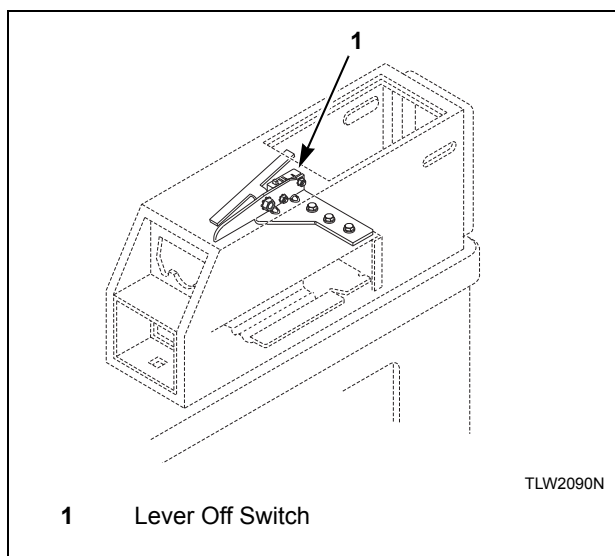

Figure 16

6. Check to make sure coin slide is operating properly by inserting coins and starting a cycle. The IN USE light will turn on, or flash if it is already on, to indicate proper operation.

**Installing Extension Onto Coin Slide:
Option 2**

1. Install coin slide according to manufacturer's instructions.
2. Insert coins into coin slide and slowly push slide in. Stop before coins fall into coin box. This will allow installing extension through meter case service door opening.
3. Install slide extension onto top of coin slide using two screws and lockwashers. Refer to *Figure 15*.

NOTE: Make sure extension lever is above switch activation lever.

4. Check to make sure coin slide is operating properly by inserting coins and starting a cycle. The IN USE light will turn on, or flash if it is already on, to indicate proper operation.

Slide Extension Assembly – Models Starting Serial No. 1211

1. Remove slide extension parts from parts accessories bag included in unit.
2. Install extension lever with arm that has one star facing down. Refer to *Figure 17*.

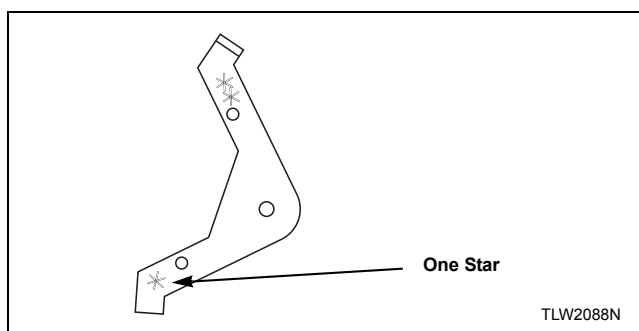

Figure 17

NOTE: If more switch down-force is required, install lever with arm that has two stars facing down to provide additional switch travel.

Installation

3. Install extension lever with rounded corner facing away from extension bracket using bolt, washer and nut. Refer to *Figure 18*.

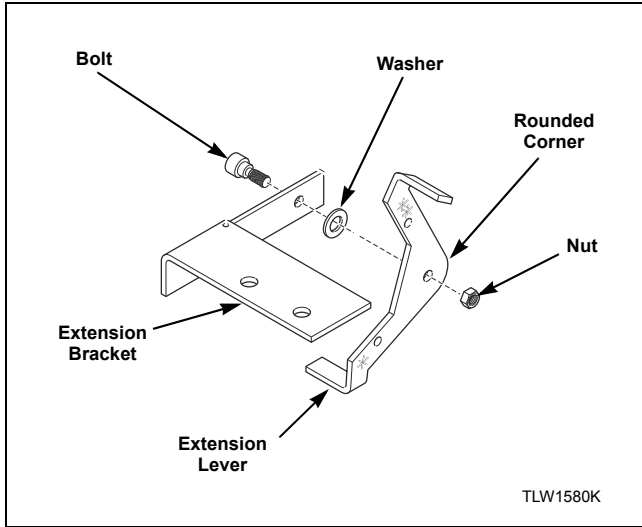

Figure 18

4. Install extension bracket and lever assembly onto coin slide bracket using two screws and locknuts. Refer to *Figure 19*.

IMPORTANT: Install coin slide bracket with side marked "A" facing up and toward extension bracket and lever assembly. Refer to *Figure 19*.

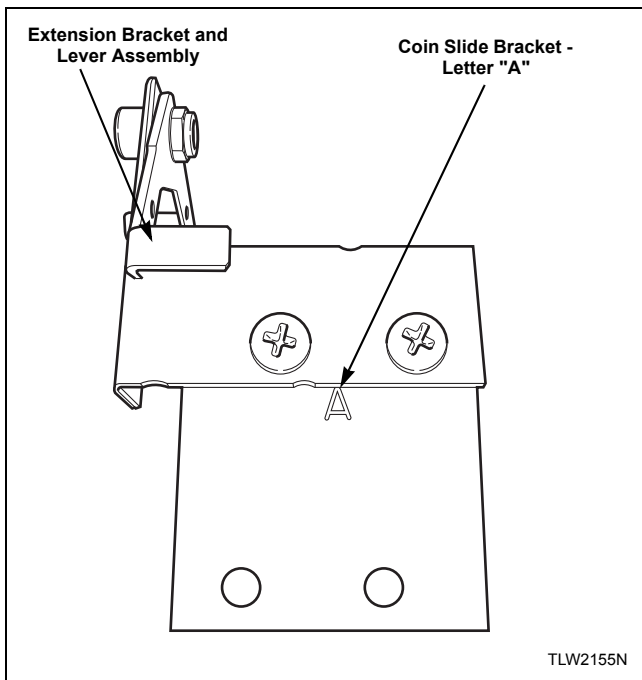

Figure 19

5. Install coin slide extension assembly onto top of coin slide using two remaining screws and lockwashers. Refer to *Figure 20*.

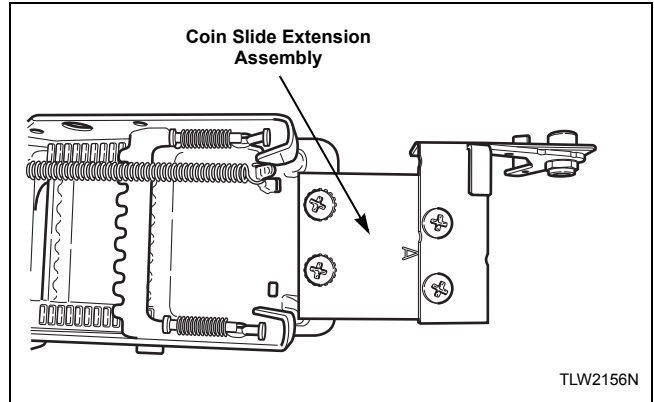

Figure 20

6. Before installing coin slide and extension, make sure ground wire is tucked under control shield to provide clearance for coin slide. Refer to *Figure 21*.

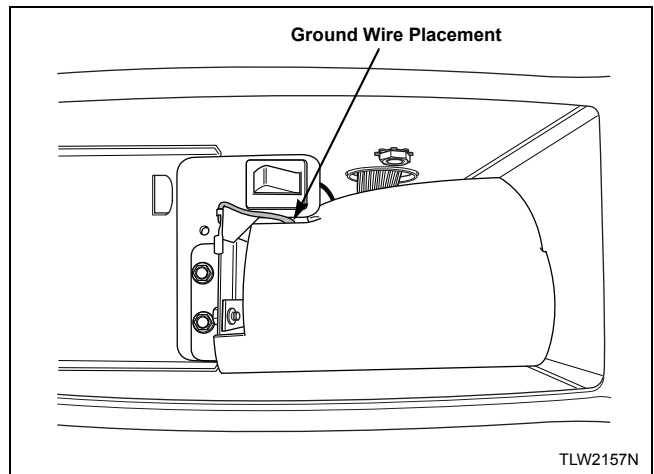

Figure 21

Installing Extension Onto Coin Slide:

Option 1

1. Insert coins and partially extend coin slide.
2. Insert coin slide on its side through meter case opening. Then rotate 90 degrees to its proper orientation.
3. Return coin slide and hook slide pins onto meter case.
4. Continue coin slide installation according to manufacturer’s instructions.
5. Check to make sure coin slide is operating properly by inserting coins and starting a cycle. The IN USE light will turn on, or flash if it is already on, to indicate proper operation.

Installing Extension Onto Coin Slide:

Option 2

1. Install coin slide according to manufacturer’s instructions.
2. Insert coins into coin slide and slowly push slide in. Stop before coins fall into coin box. This will allow installing extension through meter case service door opening.
3. Install slide extension onto top of coin slide using two screws. Refer to *Figure 20*.
4. Check to make sure coin slide is operating properly by inserting coins and starting a cycle. The IN USE light will turn on, or flash if it is already on, to indicate proper operation.

Models Prepped for Card Reader

The machine is shipped from the factory with the Electronic Control Diagnostic Harness Assembly unplugged. To avoid unauthorized manual programming or vending, perform the following steps.

1. Open control panel. Refer to *Figure 22*.
2. Locate diagnostic harness on electronic control.
3. Plug connectors for “white/black” wire and “red/blue” wire together.

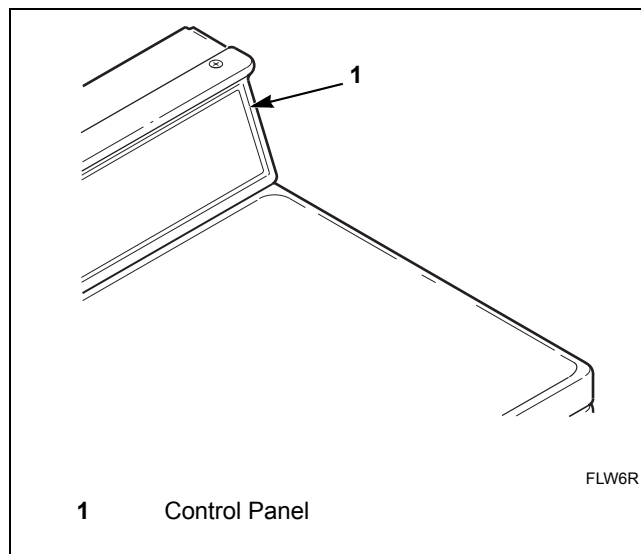

Figure 22

Installation

Additional Washer Security

(Coin Models Only)

Located on the service door of the washer is a flat Phillips head screw. During shipment, this screw is used to attach the service door to the meter case. For additional security, this screw can be reinstalled inside the control hood of your washer. Refer to instructions below for installation.

Tamper-resistant screws also can be installed for additional security. Tamper-resistant screws, bits and bit holder are available as optional equipment at extra cost. Part numbers are:

- Bit (No. 8 screws) Part No. 281P4
- Bit (No. 12 screws) Part No. 282P4
- Bit Holder (3/8 drive) Part No. 24161
- Control panel tamper-resistant screw Part No. 35528
- Front panel tamper-resistant screw Part No. 35527

The following list is the procedure required to install the Phillips head screw and tamper-resistant screws:

	WARNING
<p>Any disassembly requiring the use of tools must be performed by a suitably qualified service person.</p> <p style="text-align: right;">W299</p>	
<p>To reduce the risk of electric shock, fire, explosion, serious injury or death:</p> <ul style="list-style-type: none">• Disconnect electric power to the washer before servicing.• Never start the washer with any guards/panels removed.• Whenever ground wires are removed during servicing, these ground wires must be reconnected to ensure that the washer is properly grounded. <p style="text-align: right;">W003</p>	

1. Remove the Phillips head screw from service door (refer to *Figure 23*).
2. Remove two screws holding control panel to control hood.
3. Tilt control panel forward and lay on a protective pad to prevent scratching of cabinet top.

4. Insert Phillips head screw down through double "D" hole in left rear corner of cabinet top (inside control hood) until it engages retainer nut located on left rear corner gusset of cabinet.
5. Finger tighten screw.

IMPORTANT: Do not use a power driver to tighten screw. Torque of a power driver could over-tighten screw causing damage to cabinet assembly.

6. Secure control panel to control hood using two No. 8 tamper-resistant screws, Part No. 35528.
7. Remove two screws holding front panel to base of washer and install two No. 12 tamper-resistant screws, Part No. 35527.

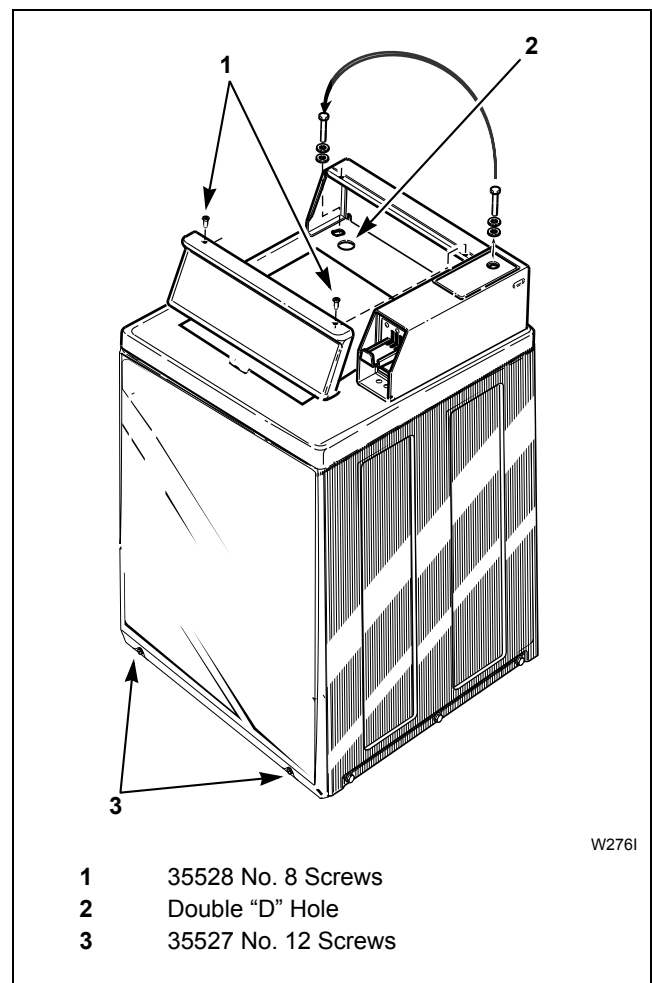

Figure 23

Operation

Operation Instructions for Coin Slide Operated and Nonmetered Washers

IMPORTANT: Prior to first wash, use an all-purpose cleaner or a detergent and water solution and a damp cloth to remove shipping dust from inside of washtub.

IMPORTANT: Remove all sharp objects from laundry to avoid tears and rips to items during normal machine operation.

Step 1: Add Detergent

Pour measured amount of detergent into washtub. Refer to package directions.

NEVER POUR UNDILUTED BLEACH DIRECTLY ON LAUNDRY. Follow package directions when using bleach.

If desired, fabric softener may be added to rinse water when RINSE light comes on.

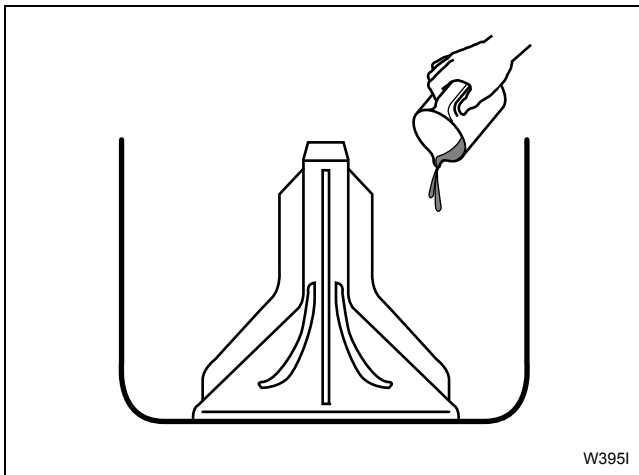

Figure 24

Step 2: Load Laundry

Load dry clothes loosely into washtub – DO NOT overload!

When washing large items such as shag rugs and bedspreads, add several small items to balance wash load.

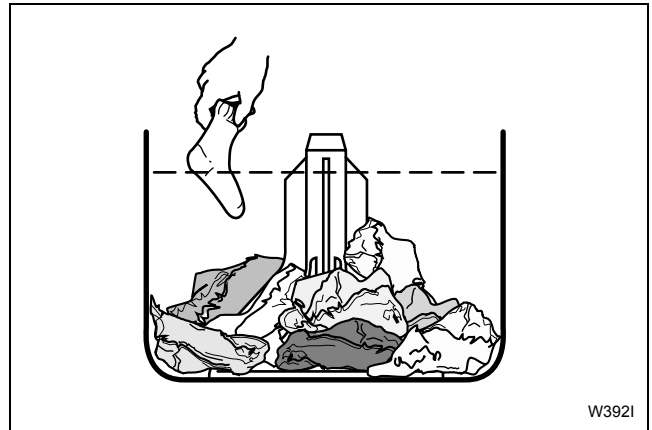

Figure 25

Step 3: Close Lid

Washer will not operate with lid open.

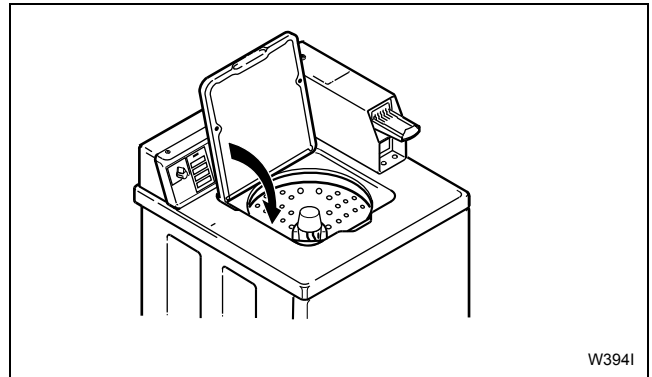

Figure 26

Operation

Step 4: Set Wash Temperature and Fabric/Cycle Selector

One Speed Washers

NOTE: Wash temperature and cycle settings may be changed any time before first wash fill is complete.

Setting Wash Temperature/Cycle

Set at either *HOT/NORMAL, *WARM/PERM PRESS, *COLD/SPECIAL, or HOT/NORMAL, WARM/PERM PRESS, COLD/SPECIAL.

Settings with asterisk (*) are Energy Saving Cycles.

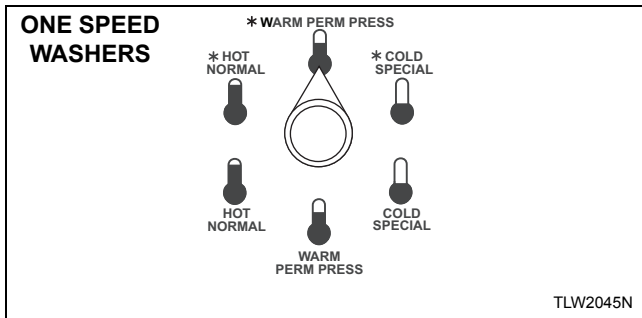

Figure 27

Two Speed Washers

NOTE: Wash temperature and fabric selector settings may be changed any time before first wash fill is complete.

Setting Wash Temperature

Set at HOT (COLD rinse), WARM (COLD rinse) or COLD (COLD rinse).

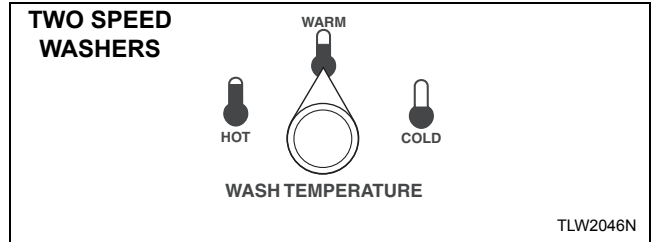

Figure 28

Setting Fabric Selector

Set Regular loads at *NORMAL, *PERM PRESS, NORMAL or PERM PRESS. Set Delicate loads at *DELICATE or DELICATE.

Settings with asterisk (*) are Energy Saving Cycles.

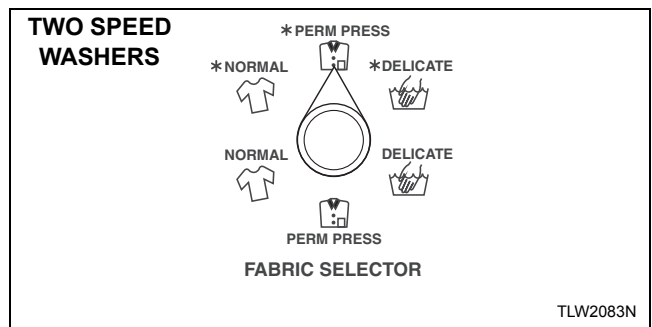

Figure 29

Step 5: Start Washer

Metered Models

Insert money. Place coin(s) in slide and carefully push in as far as possible and then pull slide out as far as possible. (*IN USE* light will come on indicating start of cycle.)

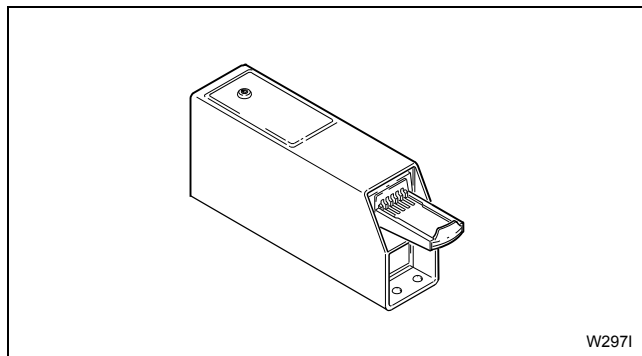

Figure 30

Nonmetered Models

Push start switch (*IN USE* light will come on indicating start of cycle.)

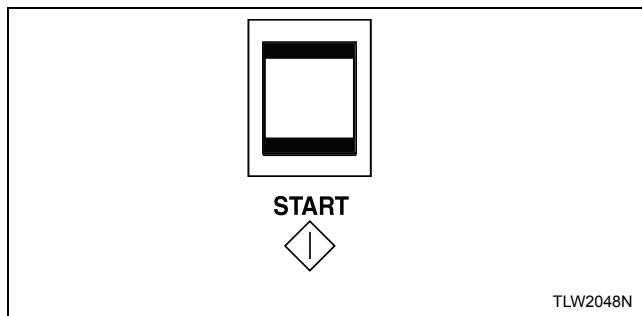

Figure 31

Indicator Lights

IN USE

This light will remain on while washer is in use.

RINSE

This light will be on during the rinse portion of the cycle.

SPIN

This light will be on during the rinse/final spin only. Washer will stop automatically at end of cycle. (SPIN and *IN USE* lights will go out indicating end of cycle.) Leave lid open after removing laundry.

IMPORTANT: If washer fails to operate properly after installation, make sure electrical service and water supply faucets are turned on. Are all the controls properly set? Have a qualified service person refer to the wiring diagram (located inside of washer control hood), check for broken, loose or incorrect wiring.

Should washer stop, but *IN USE*, RINSE or SPIN light remain on, the motor overload protector may have cycled. Refer to *Maintenance* section.

	WARNING
<p>To reduce the risk of bodily injury, do not remove laundry from washer until all lights are out, and all moving parts have stopped.</p>	
W092	

The washer will stop (pause) shortly before the first spin and final spin.

Operation

Control Modes

Power-Up Mode

The control enters this mode after power is applied to the washer. In Power-Up Mode, the control will detect the state it was in at power-down to determine what mode to enter. After the control completes operation in the Power-Up Mode, it will enter either the Ready, Test or Run Modes.

Ready Mode

In Ready Mode, the control will wait for the vend to be satisfied before entering Run Mode.

Run Mode

In Run Mode, the control is running a cycle. The *IN USE* LED will be lit. For metered models, any time the control receives a coin slide pulse during a cycle, the *IN USE* LED will flash briefly to indicate the coin input. For nonmetered models, any time the control receives a pulse from the push-to-start switch during a cycle, the *IN USE* LED will flash briefly to indicate the push-to-start input.

Lid Open Mode

The control enters Lid Open Mode when the lid is opened during Run Mode. All cycle activity is stopped. The cycle time count down stops unless the lid is opened during the last three minutes of the final spin step. In this case the time will continue to count down.

End of Cycle Mode

The control enters End of Cycle Mode when a cycle is complete. The *IN USE* LED will be off. The control will remain in this mode until the lid is opened or vend has been satisfied.

Error Mode

In Error Mode, the *IN USE* LED flashes to display fill and drain errors (refer to paragraphs below). Error Mode can only be exited by powering down washer. The Error Mode can be turned off by setting dipswitch 2 to the CLOSED position. Refer to *Table 1*.

Fill Error

A Fill Error will occur if the tub does not fill within 62 minutes of the start of the cycle. A Fill Error is indicated by the control flashing the *IN USE* LED twice separated by a one and a half second pause until the control is powered down. If Error Mode is turned off (refer to *Table 1*), the fill error will not occur and the control will continue to wait for the fill level to be reached.

Drain Error

A Drain Error will occur if the tub is not empty after a spin cycle. A Drain Error is indicated by the control flashing the *IN USE* LED three times separated by a one and a half second pause until the control is powered down. If Error Mode is turned off (refer to *Table 1*), the drain error will not occur and the machine cycle will advance to the next cycle step as though the water had been pumped out.

Rapid Advance

The Rapid Advance feature allows the owner to quickly advance into a cycle and advance an active cycle to a specific cycle step.

To enter Rapid Advance and advance through each cycle step, open the meter case service door (on metered models) or the control hood (on nonmetered models), unplug the white bullet connector with the black/white and gray/yellow wires on the hood wire harness for at least one second, and then reconnect it. Each time the connector is unplugged and reconnected, the control will advance through the following steps:

- From Ready Mode, cycle will advance to wash fill (start of cycle).
- From wash fill or agitate, cycle will advance to wash spin following a short pause. Wait for pause and washer to spin before advancing to next step.
- From wash spin, cycle will advance to rinse fill.
- From rinse fill or agitate, cycle will advance to final spin following a short pause. Wait for pause and washer to spin before advancing to next step.
- From final spin, cycle will advance to End of Cycle Mode.
- Open lid to clear End of Cycle Mode and return to Ready Mode.

Setting Dipswitch

Cycle settings can be changed using the 8-Position dipswitch mounted on the control. The control reads the dipswitch settings at power-up. The control must be powered down to change the dipswitch settings. The control is shipped from the factory with all the switches in the OPEN position. Refer to the table below for dipswitch settings.

Switch 1 is used to select whether a long or short cycle will be used. Switch 2 is used to turn Error Mode on or off. Switches 3 through 8 are not used at this time.

Switch No.	Open (Default)	Closed
1	Long Cycle	Short Cycle
2	Error Mode On	Error Mode Off
3-8	Not Used	

Table 2

Operation

Operation Instructions for Electronic Display Control Washers

IMPORTANT: Prior to first wash, use an all-purpose cleaner or a detergent and water solution and a damp cloth to remove shipping dust from inside of washer.

IMPORTANT: Remove all sharp objects from laundry to avoid tears and rips to items during normal machine operation.

Step 1: Add Detergent

Pour measured amount of detergent into washtub. Refer to package directions.

NEVER POUR UNDILUTED BLEACH DIRECTLY ON LAUNDRY. Follow package directions when using bleach.

If desired, fabric softener may be added to rinse water when RINSE light comes on.

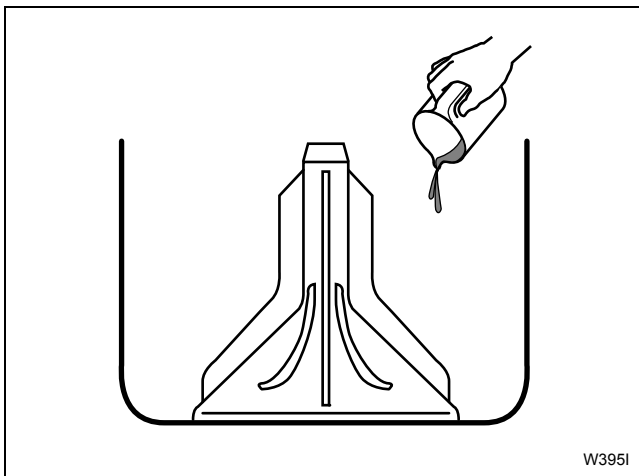

Figure 32

Step 2: Load Laundry

Load dry clothes loosely into washtub – DO NOT overload!

When washing large items such as shag rugs and bedspreads, add several small items to balance wash load.

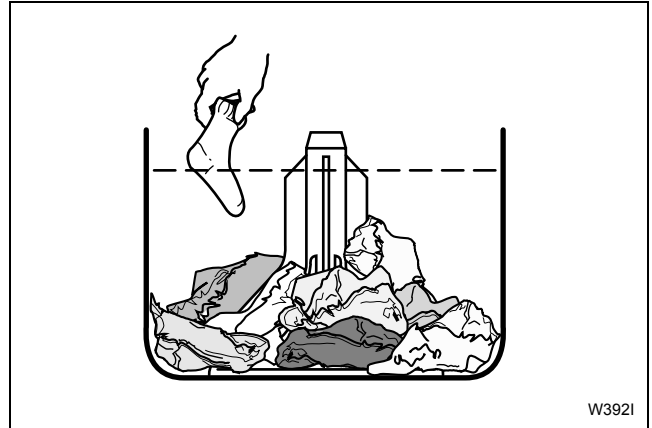

Figure 33

Step 3: Close Lid

Washer will not operate with lid open.

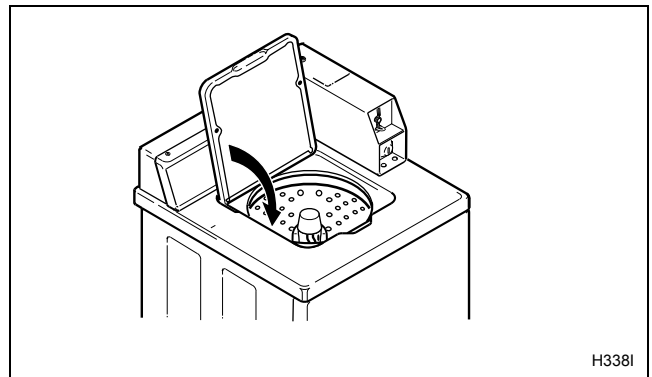

Figure 34

Step 4: Choose Small Load, if Desired

Press SMALL LOAD button. SMALL LOAD indicator light will be lit.

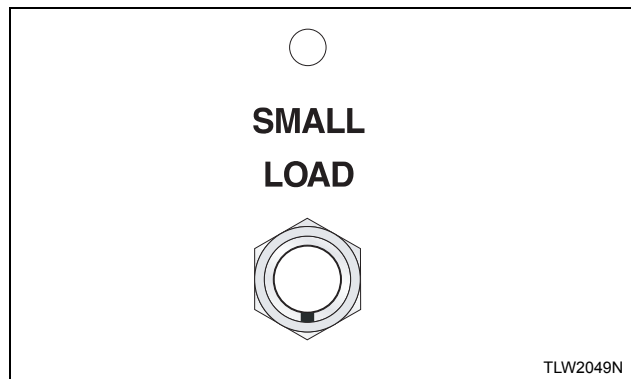

Figure 35

Any time the lid is opened, the SMALL LOAD option will turn off and the washer will fill to the normal level. The SMALL LOAD indicator light will be off.

Step 5: Set Fabric Selector

Push touchpad for NORMAL, PERM PRESS or DELICATES. Light indicates selection.

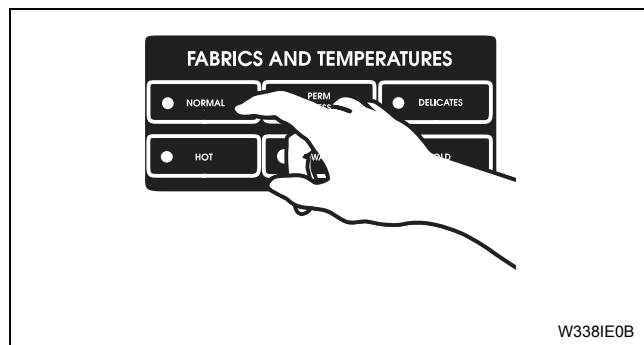

Figure 36

Step 6: Set Wash Temperature

Push touchpad for HOT, WARM or COLD. Light indicates selection.

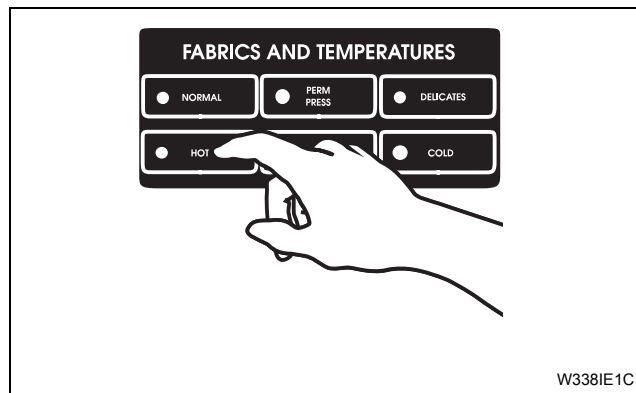

Figure 37

Step 7: Insert Money

Insert coin(s) in coin slot. Check pricing as seen on digital display. LID MUST BE CLOSED TO START WASHER.

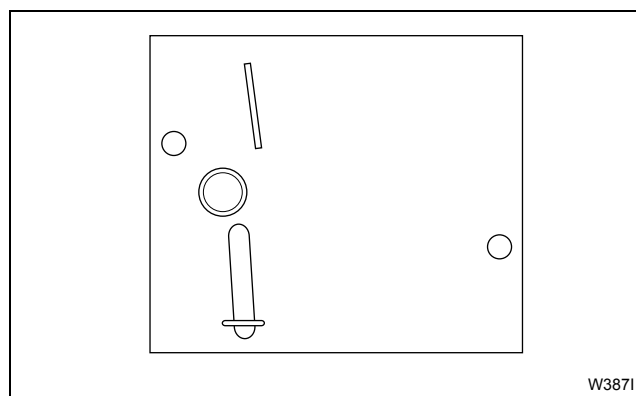

Figure 38

Operation

Indicator Lights

WASH

WASH is lit at the beginning of a Wash cycle and will remain lit until the Wash cycle is complete.

RINSE

RINSE is lit at the beginning of the Rinse or Extra Rinse cycle and will remain lit until the cycle is complete.

SOAK

SOAK is lit at the beginning of all Pause cycles. During a Wash Pause cycle, the display will light “WASH SOAK” and during a Rinse or Extra Rinse Pause cycle, the display will light “RINSE SOAK.”

SPIN

SPIN is lit for all Spin cycles. During a Wash Spin cycle, the display will light “WASH SPIN” and during an Extra Rinse Spin Cycle, the display will light “RINSE SPIN”. At the beginning of Final Spin, the display will light “SPIN.”

PRICE

PRICE is lit to indicate that value displayed is the vend price remaining to be satisfied. Once the vend price is satisfied, the word “PRICE” will go off.

TIME REMAINING

TIME REMAINING is lit to indicate that the number displayed by two digits and the colon is the time remaining in the current cycle. It will light at the start of the cycle and remain lit until the cycle is completed.

INSERT COINS

INSERT COINS is lit to prompt the user for coins to satisfy the vend price. When *INSERT COINS* is lit, the three digits and decimal point show the vend price remaining to be satisfied.

UNBALANCE

UNBALANCE is lit and will flash when the washer is in a Spin mode and the lid is opened.

IMPORTANT: If washer fails to operate properly after installation, make sure electrical service and water supply faucets are turned on. Are all the controls properly set? Have a qualified service person refer to the wiring diagram (located inside of washer control hood) and check for broken, loose or incorrect wiring.

Should washer stop, but *IN USE*, *RINSE* or *SPIN* light remain on, the motor overload protector may have cycled. Refer to *Maintenance* section.

	WARNING
To reduce the risk of bodily injury, do not remove laundry from washer until all lights are out, and all moving parts have stopped.	
<small>W092</small>	

The washer will stop (pause) shortly before the first spin and final spin.

Operation Instructions for MDC Washers

IMPORTANT: Prior to first wash, use an all-purpose cleaner, or a detergent and water solution, and a damp cloth to remove shipping dust from inside of washer.

IMPORTANT: Remove all sharp objects from laundry to avoid tears and rips to items during normal machine operation.

Step 1: Add Detergent

Pour measured amount of detergent into washtub. Refer to package directions.

NEVER POUR UNDILUTED BLEACH DIRECTLY ON LAUNDRY. Follow package directions when using dry bleach.

If desired, fabric softener may be added to rinse water when RINSE light comes on.

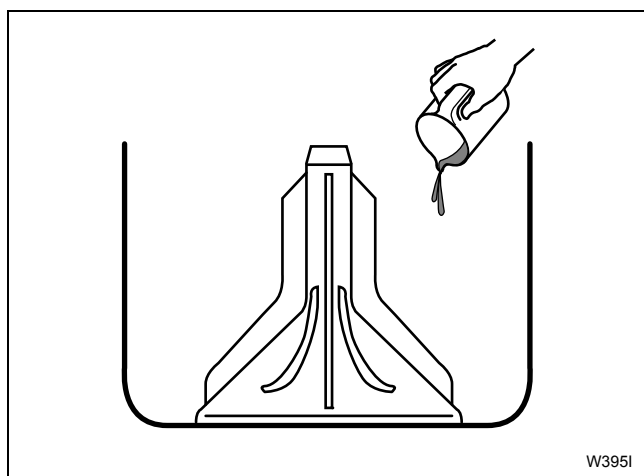

Figure 39

Step 2: Load Laundry

Load dry clothes loosely into washtub – DO NOT overload!

When washing large items such as shag rugs and bedspreads, add several small items to balance wash load.

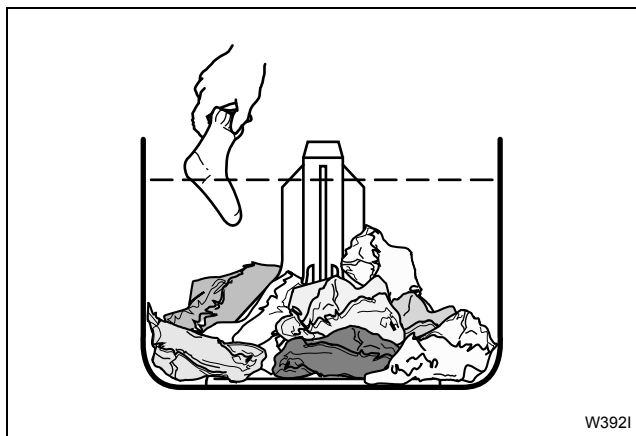

Figure 40

Step 3: Close Lid

Washer will not operate with lid open.

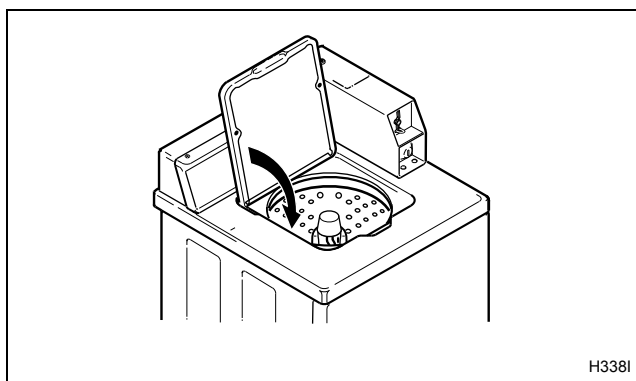

Figure 41

Operation

Step 4: Choose Small Load, if Desired

If available, press SMALL LOAD button. SMALL LOAD indicator light will be lit.

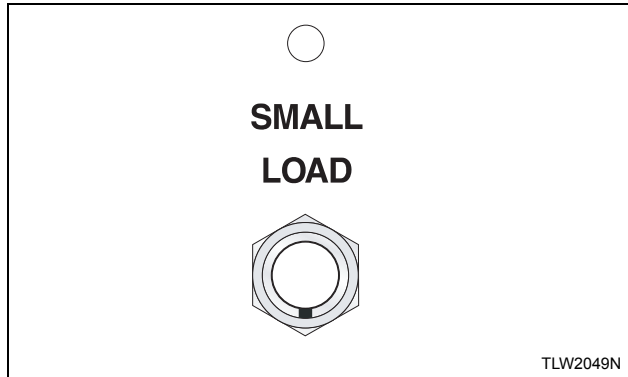

Figure 42

Any time the lid is opened, the SMALL LOAD option will turn off and the washer will fill to the normal level. The SMALL LOAD indicator light will be off.

Step 5: Set Fabric Selector and Wash Temperature

Push touchpad for NORMAL/HOT, NORMAL/WARM, PERM PRESS/WARM or DELICATES/COLD. Light indicates selection.

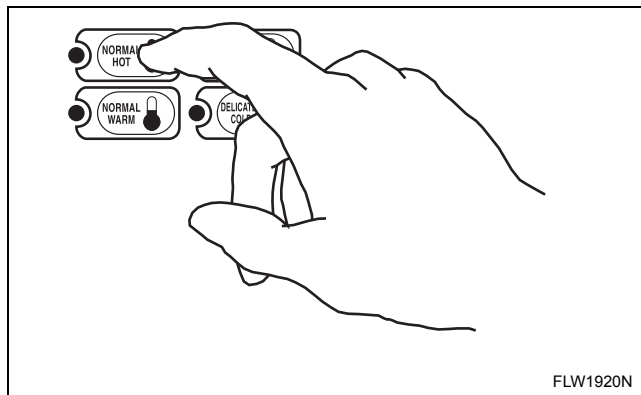

Figure 43

Step 6: Insert Money or Card

To Insert Money

Insert coin(s) in coin slot. Check pricing as seen on digital display.

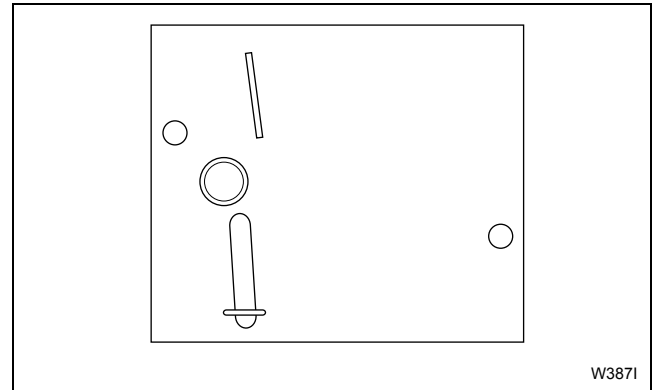

Figure 44

To Insert Card

Insert card into opening.

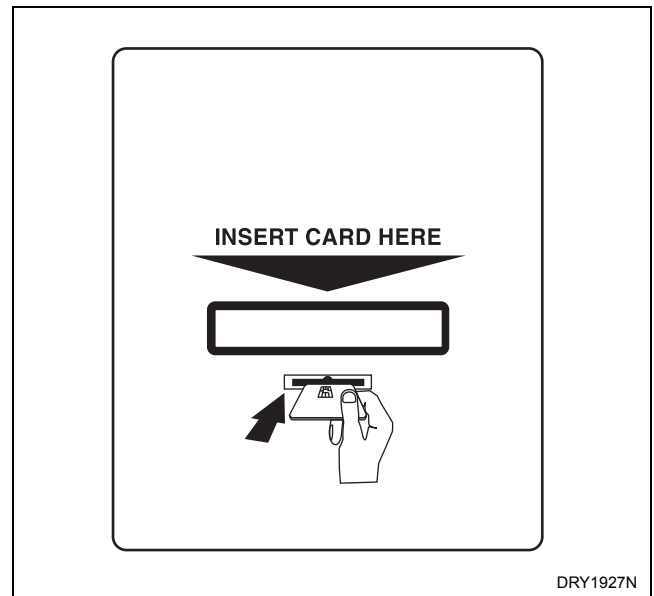

Figure 45

Step 7: Start Washer

After vend price has been satisfied, push the START pad. LID MUST BE CLOSED TO START WASHER.

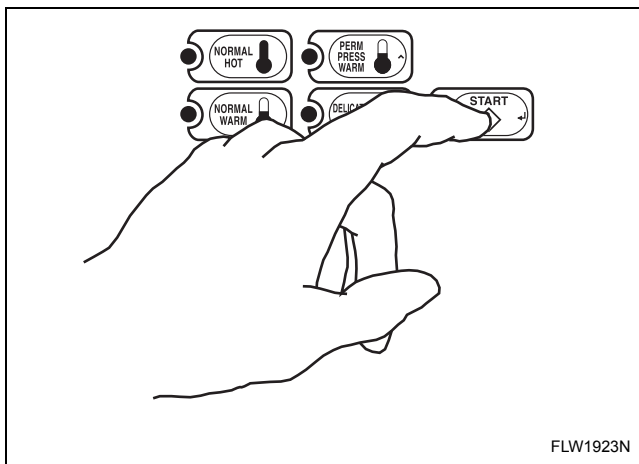

Figure 46

Indicator Lights

WASH

WASH is lit at the beginning of a Wash cycle and will remain lit until the Wash cycle is complete.

RINSE

RINSE is lit at the beginning of the Rinse cycle and will remain lit until the cycle is complete.

SPIN

SPIN is lit for all Spin cycles.

Operation

Operation Instructions for NetMaster Washers

IMPORTANT: Prior to first wash, use an all-purpose cleaner, or a detergent and water solution, and a damp cloth to remove shipping dust from inside of washer.

IMPORTANT: Remove all sharp objects from laundry to avoid tears and rips to items during normal machine operation.

Step 1: Add Detergent

Pour measured amount of detergent into washtub. Refer to package directions.

NEVER POUR UNDILUTED BLEACH DIRECTLY ON LAUNDRY. Follow package directions when using dry bleach.

If desired, fabric softener may be added to rinse water when RINSE light comes on.

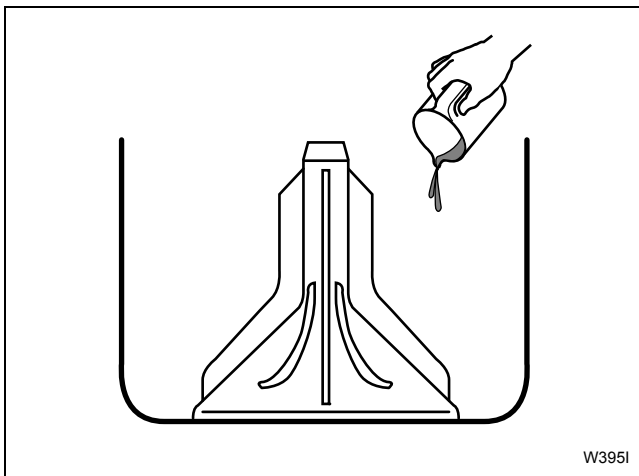

Figure 47

Step 2: Load Laundry

Load dry clothes loosely into washtub – DO NOT overload!

When washing large items such as shag rugs and bedspreads, add several small items to balance wash load.

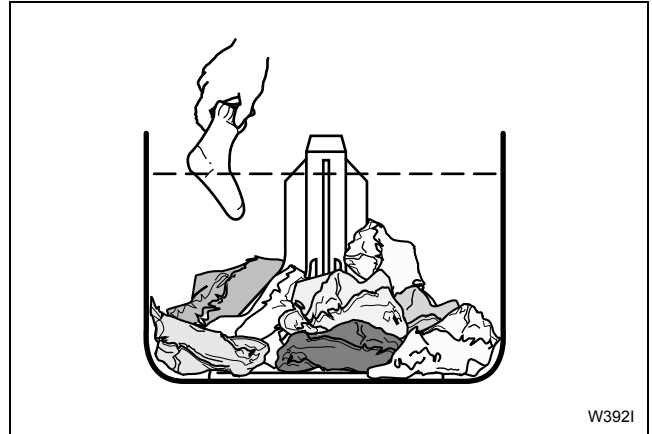

Figure 48

Step 3: Close Lid

Washer will not operate with lid open.

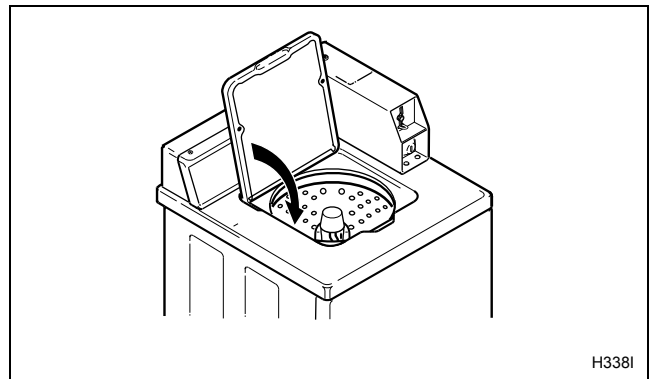

Figure 49

Step 4: Choose Small Load, if Desired

Press SMALL LOAD button. SMALL LOAD indicator light will be lit.

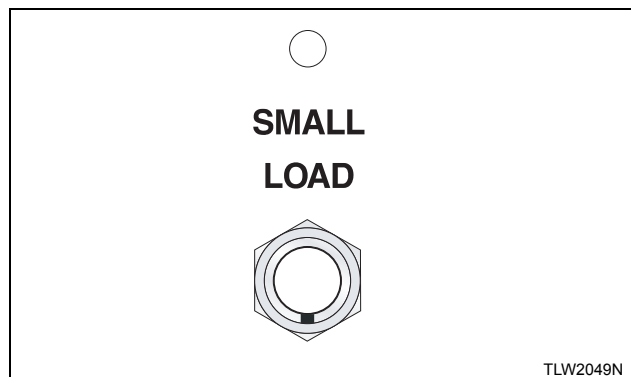

Figure 50

Any time the lid is opened, the SMALL LOAD option will turn off and the washer will fill to the normal level. The SMALL LOAD indicator light will be off.

Step 5: Set Fabric Selector

Push touchpad for NORMAL, PERM PRESS or DELICATES. Light indicates selection.

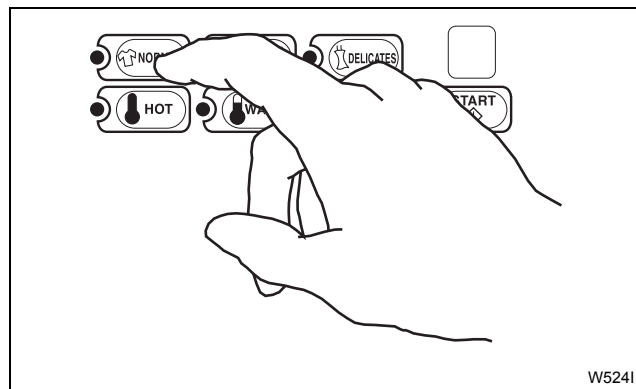

Figure 51

Step 6: Set Wash Temperature

Push touchpad for HOT, WARM or COLD. Light indicates selection.

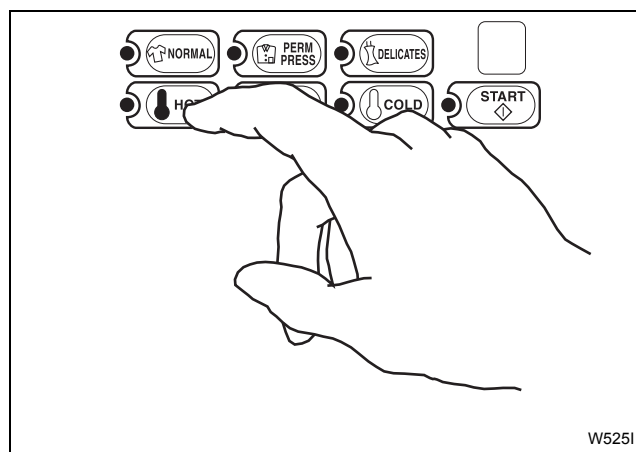

Figure 52

Operation

Step 7: Insert Money or Card

To Insert Money

Insert coin(s) in coin slot. Check pricing as seen on digital display.

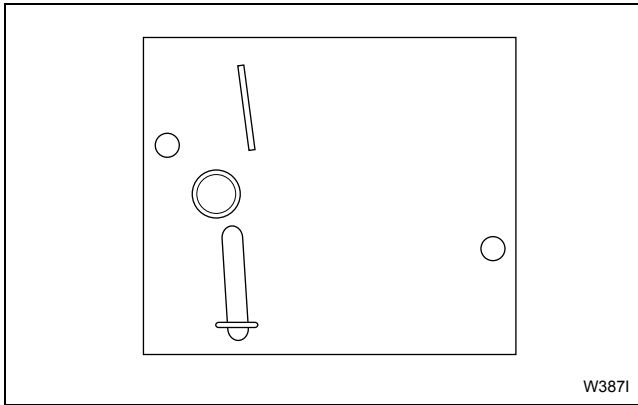

Figure 53

To Insert Card

Insert card into opening. **DO NOT REMOVE THE CARD UNTIL REMOVE CARD LED is lit.**

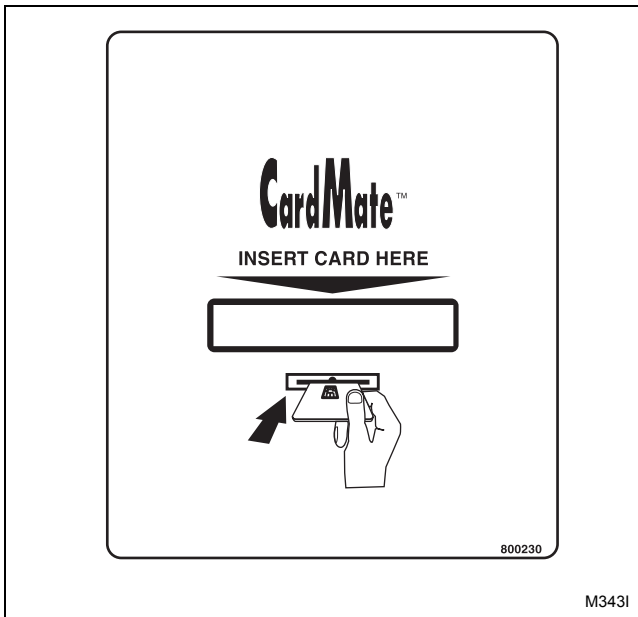

Figure 54

Step 8: Start Washer

After vend price has been satisfied, push the START pad. **LID MUST BE CLOSED TO START WASHER.**

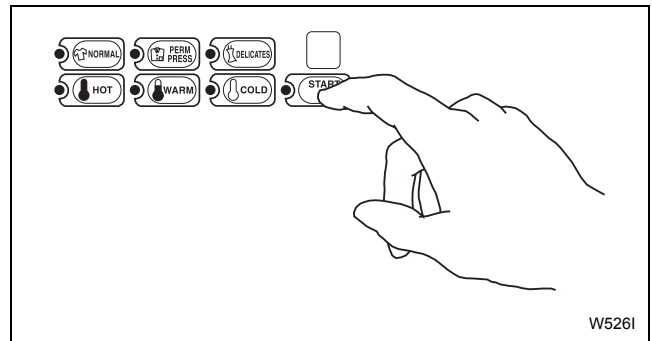

Figure 55

Indicator Lights

WASH

WASH is lit at the beginning of a Wash cycle and will remain lit until the Wash cycle is complete.

RINSE

RINSE is lit at the beginning of the Rinse or Extra Rinse cycle and will remain lit until the cycle is complete.

SPIN

SPIN is lit for all Spin cycles.

INSERT COINS/INSERT CARD

INSERT COINS/INSERT CARD is lit to prompt the user to insert coins or a card to satisfy the vend price. When *INSERT COINS/INSERT CARD* is lit, the digits and decimal point show the vend price remaining to be satisfied.

REMOVE CARD (Card Models Only)

REMOVE CARD flashes after the START pad has been pressed and the vend has been deducted from the card.

Maintenance

User-Maintenance Instructions

Cold Weather Care

If the washer is delivered on a cold day (below freezing), or is stored in an unheated room or area during the cold months, do not attempt to operate the washer until it has had a chance to warm up.

Care of Your Washer

Use only a damp or sudsy cloth for cleaning the control panel. Some cleaning products may harm the finish on the control panel. **DO NOT** use products that contain alcohol on the control panel. Wipe the panel dry after cleaning.

Wipe the washer cabinet as needed. If detergent, bleach or other washing products are spilled on the cabinet, wipe immediately. Some products will cause permanent damage if spilled on the cabinet.

Do not use scouring pads or abrasive cleansers.

The washtub will need no particular care though it may need rinsing or wiping after some unusual loads have been washed. This also may be necessary if too little detergent has been used.

Leave the lid open to allow the inside of the washer to dry out after use. This helps prevent musty odors from developing.

The agitator should not be removed except for service. The washtub is designed to be self cleaning.

Replacing Hoses

Hoses and other natural rubber parts deteriorate after extended use. Hoses may develop cracks, blisters or material wear from the temperature and constant high pressure they are subjected to.

All hoses should be checked on a monthly basis for any visible signs of deterioration. Any hose showing the signs of deterioration listed above should be replaced immediately. All hoses should be replaced every five years.

Filter Screens

Check the filter screens in the fill hoses for debris or damage annually. Clean or replace them if necessary.

If the washer is filling with water slower than normal, check the filter screens. Clean or replace them if necessary.

Order filter screen Part No. F270300 from the nearest authorized parts distributor.

Reinstallation of Shipping Materials

Shipping Brace

The shipping brace in the lid opening should be **saved** and reinstalled whenever the washer is moved. To reinstall the brace, open the washer lid and place the brace over the washer agitator, placing the back of the brace into the lid opening first.

Shipping Plug

The plastic shipping plug should be saved and reinstalled any time the washer is moved. The plug fits into two openings: The base opening and the shipping plug opening on the bottom of the movable pivot dome. The plug **MUST** be inserted into both openings to prevent damage to the washer. In order to accomplish this, the shipping plug opening must be directly lined up with the base opening. Refer to *Figure 56*.

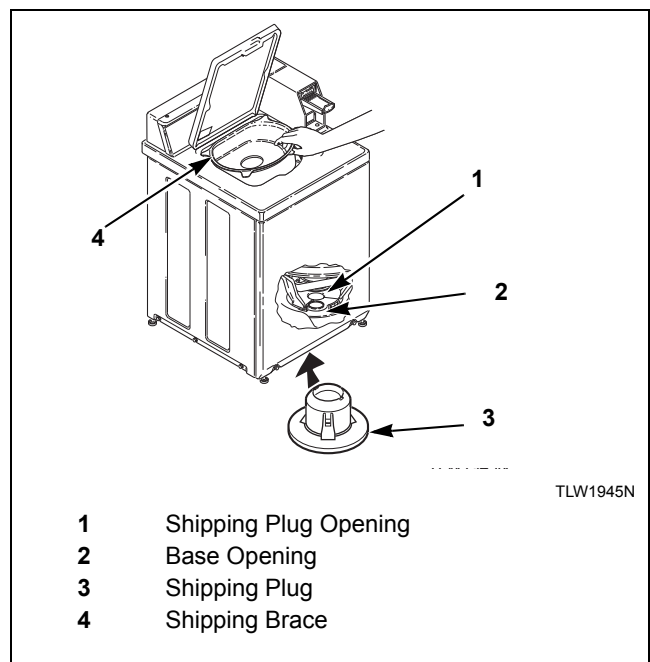

Figure 56

Motor Overload Protector

The internal overload protector will stop the motor automatically in the event of an overload.

The overload protector will reset itself in two or three minutes and the motor will restart automatically.

If the overload protector stops motor again, remove the washer from use and call the service person to correct the problem.

Troubleshooting

Try these troubleshooting tips before making a service call. They may save you time and money.

Washer Symptom	Possible Cause/Solution
Won't Fill	<ul style="list-style-type: none"> • Make sure lid is closed. • Make sure power cord is plugged all the way into the electrical outlet. • Make sure hot and cold water faucets are turned on. • Make sure that the fill hoses are not kinked or twisted. • Place coin(s) in slide or drop (metered models only). • Push START switch to start the washer (nonmetered models only). • Make sure that the controls are properly set. • Make sure that the last spin has been completed. • Check the laundry room fuse or circuit breaker. • Clean the screens in the water mixing valve and the filter screens located at the faucet end of the fill hoses. • Water is being siphoned from the washer during the cycle. Refer to the <i>Installation</i> section to make sure that the drain hose has been properly installed. • The motor overload protector may have stopped the cycle. It will reset itself in two or three minutes and restart the washer automatically.
Won't Start	<ul style="list-style-type: none"> • Make sure lid is closed. • Place coin(s) in slide or drop (metered models only). • Push START switch to start the washer (nonmetered models only). • Make sure power cord is plugged all the way into the electrical outlet. • Make sure that the controls are properly set. • Check the laundry room fuse or circuit breaker. • The motor overload protector may have stopped the cycle. It will reset itself in two or three minutes and restart the washer automatically.
Won't Agitate	<ul style="list-style-type: none"> • Make sure lid is closed. • Place coin(s) in slide or drop (metered models only). • Push START switch to start the washer (nonmetered models only). • Make sure power cord is plugged all the way into the electrical outlet. • Check the laundry room fuse or circuit breaker. • The motor overload protector may have stopped the cycle. It will reset itself in two or three minutes and restart the washer automatically. • Broken drive belt. Call the service person. • Have a qualified electrician check polarity and grounding. Refer to <i>Electrical Requirements</i> section.
Won't Spin	<ul style="list-style-type: none"> • Make sure lid is closed. • Place coin(s) in slide or drop (metered models only). • Push START switch to start the washer (nonmetered models only). • Make sure power cord is plugged all the way into the electrical outlet. • Check the laundry room fuse or circuit breaker. • The motor overload protector may have stopped the cycle. It will reset itself in two or three minutes and restart the washer automatically. • Broken drive belt. Call the service person. • Have a qualified electrician check polarity and grounding. Refer to <i>Electrical Requirements</i> section.
Stops/Pauses During Cycle	<ul style="list-style-type: none"> • Pauses are part of the washer's normal operation. The washer will stop (pause) shortly before the wash and rinse spins. • Check the laundry room fuse or circuit breaker. • The motor overload protector may have stopped the cycle. It will reset itself in two or three minutes and restart the washer automatically.

Washer Symptom	Possible Cause/Solution
Won't Drain	<ul style="list-style-type: none"> • Make sure drain hose is not kinked or twisted. • Make sure drain hose is not clogged. • Make sure drain receptacle is not clogged. • Refer to the <i>Installation</i> section to make sure that the drain hose has been properly installed.
Water Leaks	<ul style="list-style-type: none"> • Check that fill hoses are properly installed on the faucets and the washer's water mixing valve. • Replace the fill hoses every five years. • Make sure drain receptacle is not clogged. • Check laundry room plumbing. • Laundry load may be oversudsing or overloaded. Use less detergent (or low-sudsing detergent) and proper load sizes.
Is Noisy	<ul style="list-style-type: none"> • Wash load may be unbalanced. Open lid and redistribute the load. • Make sure washer is level. Uneven leveling can cause vibration. • A newly installed washer may make a knocking sound if the machine has been in storage. The belt may have settled. Run washer through 4-5 cycles to loosen belt. Washer operation will not be affected.
Load is too Wet	<ul style="list-style-type: none"> • Wash load may be unbalanced. Open lid and redistribute the load. • Load is too small. Add items to make full load.
Wrong Water Temperature	<ul style="list-style-type: none"> • Make sure that the controls are properly set. • Check fill hoses. Make sure hot faucet hose is connected to hot mixing valve (indicated with "H" on the valve bracket) and cold faucet is connected to cold mixing valve (indicated with "C" on the valve bracket). • Make sure laundry room water heater is adjusted properly.

Contact Information

If service is required, contact the nearest Factory Authorized Service Center.

If you are unable to locate an authorized service center or are unsatisfied with the service performed on your unit, contact:

Alliance Laundry Systems
Shepard Street
P.O. Box 990
Ripon, WI 54971-0990
U.S.A.
www.comlaundry.com
Phone: (920) 748-3121

When calling or writing about your unit, PLEASE GIVE THE MODEL AND SERIAL NUMBERS. The model and serial numbers are located on the nameplate. The nameplate will be in the location shown in *Figure 57*.

Date Purchased _____

Model Number _____

Serial Number _____

Please include a copy of your bill of sale and any service receipts you have.

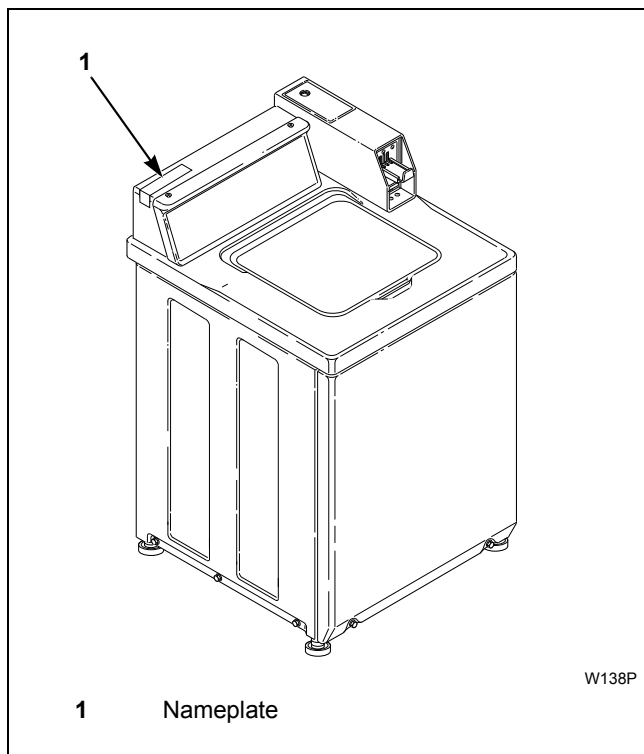

Figure 57



WARNING

To reduce the risk of serious injury or death, DO NOT repair or replace any part of the unit or attempt any servicing unless specifically recommended in the user-maintenance instructions or in published user-repair instructions that you understand and have the skills to carry out.

W329

If replacement parts are required, contact the source from where you purchased your washer or call (920) 748-3950 for the name and address of the nearest authorized parts distributor.

Installer Checklist

Fast Track for Installing the Washer
(Refer to the manual for more detailed information)

1 • Remove the Shipping Brace and Shipping Plug.

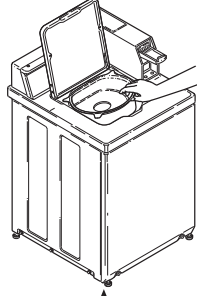

CHECK

TLW520N

5 • Position and Level the Washer.

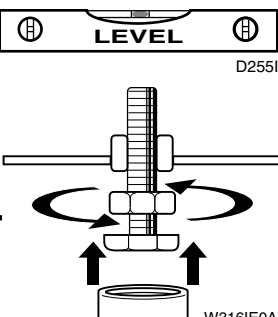

CHECK

D255I
W316IE0A

2 • Wipe Out Inside of Washtub.

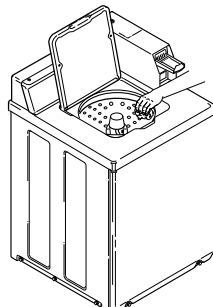

CHECK

W396IE0A

6 • Plug In the Washer.

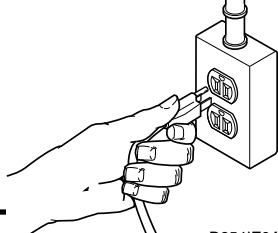

CHECK

D254IE0A

3 • Connect Fill Hoses.

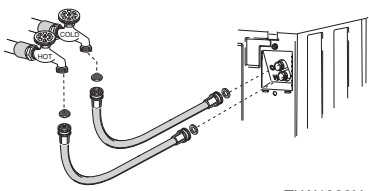

CHECK

TLW1988N

7 • Add Water to the Washer.

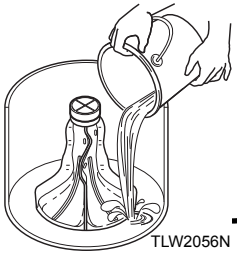

CHECK

TLW2056N

4 • Connect Drain Hose to Drain Receptacle.

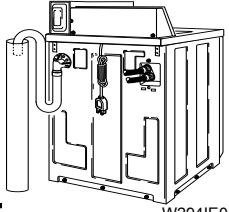

CHECK

W294IE0A

8 • Check Lid Switch.

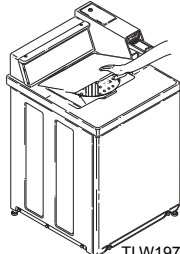

CHECK

TLW1974N