

Blast Chillers / Freezers

ALEX1

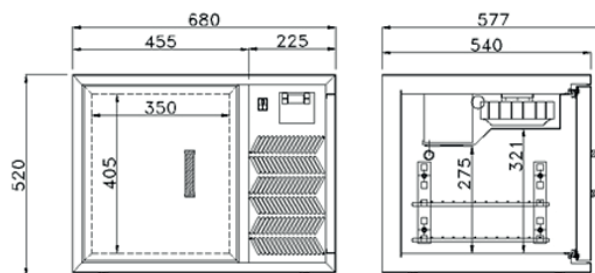

**304
STAINLESS
STEEL**

	Blast chilling (per cycle)	Blast freezing (per cycle)
ALEX1	0.96KWh	0.81KWh
ALEX2	1.92KWh	3.50KWh

ALEX2

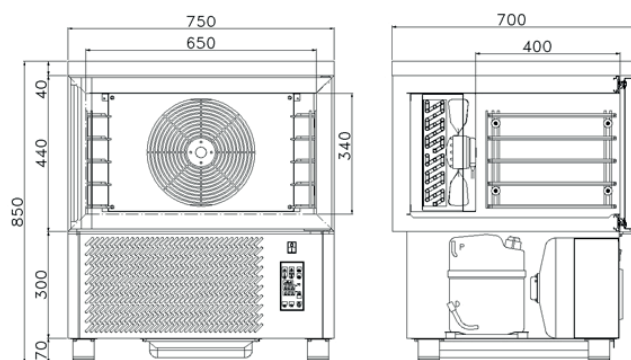

FEATURES

High grade AISI 304 stainless steel exterior & interior

ALEX1: 2 x shelves as standard accepts GN2/3 trays (not supplied)

ALEX2, 3 & 4: 1 x GN1/1shelf and 1 x 400mm x 595mm shelf as standard; accepts GN1/1 or 600mm x 400mm trays (not supplied)

For optimal result, it's recommended to use 25mm deep gastronorm containers (not supplied)

Temperature probe

Replaceable door gasket

TECHNICAL SPECIFICATIONS

Cycle Time: Blast chill cycle +70 to +3°C in 90 minutes
Blast freeze cycle +70 to -18°C in 240 minutes

Controller: Digital controller with temperature display

Cooling: Ventilated

Defrost: Automatic

Refrigerant: R452a

Climate Class: 4

Temperature Range: +70°C ~ -18°C

Power Supply: 13amp - ALEX 1, ALEX2
15amp - ALEX3
20amp - ALEX4



See page 9
for full GN
container range

Blast Chillers / Freezers

ALEX3

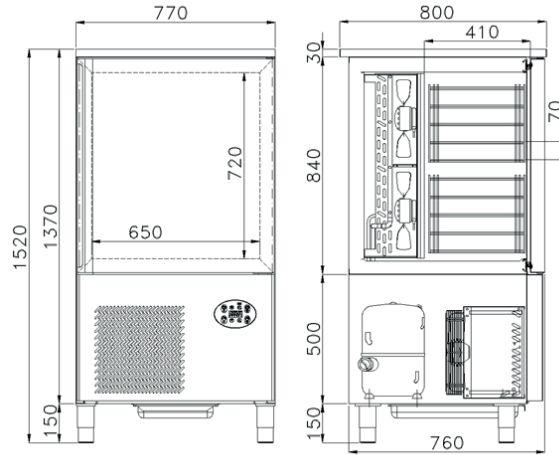

	Blast chilling (per cycle)	Blast freezing (per cycle)
ALEX3	3.00KWh	5.58KWh
ALEX4	4.05KWh	8.64KWh

304 STAINLESS STEEL

ALEX4

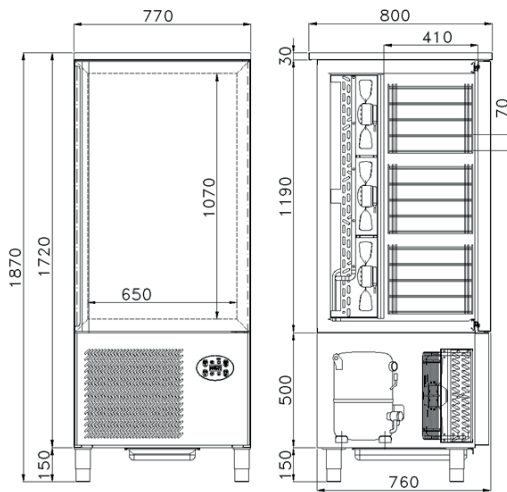

MODEL	CHILL CYCLE (90 mins)	FREEZE CYCLE (240 mins)	CONTAINER CAPACITY	EXTERNAL DIMENSIONS (H x W x D mm)	POWER CONSUMPTION	WEIGHT (kg)	RRP
ALEX1	8 kg	3 kg	2 x GN2/3	520 x 680 x 540	560W	73	
ALEX2	16 kg	10 kg	5 x GN1/1	850 x 750 x 700	900W	107	
ALEX3	30 kg	18 kg	10 x GN1/1	1520 x 770 x 800	1419W	190	
ALEX4	45 kg	27 kg	15 x GN1/1	1870 x 770 x 800	2660W	216	



See page 9 for full GN container range