

MODEL T28C

SOFT SERVE FREEZER

PASTEURISATION MACHINE

REQUIRES CLEANING ONLY EVERY 21 DAYS



deal for **lightly staffed convenience stores**, perfectly suited to QSR market, leisure venues and the convenience sector



FAST FREEZE DOWN

Patented high efficiency heat exchanger allows fast freeze down with low energy consumption



STANDBY

Maintains product temperature in both mix hopper and freezing cylinder below 4.4°C (40°F) overnight



PUMP FEED

Gear pump mechanically injects proper amount of air to generate consistent and high overrun to ensure smooth and creamy product texture



HOPPER AGITATOR

Maintain product consistency & prevent product separation



SOFT SYSTEM START

Slow motor start reduces equipment noise and stress on drive train



DEFROST FOR CLEANING

Increases efficiency during cleaning by heating frozen product in cylinder



SELF CLOSING VALVE W/ SPEED CONTROL

Automatically prevents product overflow after dispense; Provides flexibility in dispense rate control



SAFETY PROTECTIONS

- Low temperature and motor overload shut-off to protect in the event of cylinder freeze up
- High pressure switch to prevent compressor overheating

FULLY AUTOMATIC, **HIGHLY VERSATILE**, SELF SERVICE SOFT SERVE MACHINE MANUFACTURED TO ILLUMINATE LABOUR AND OPERATIONAL ISSUES

MAXIMISE YOUR PROFITS

MODEL T28C

SOFT SERVE FREEZER

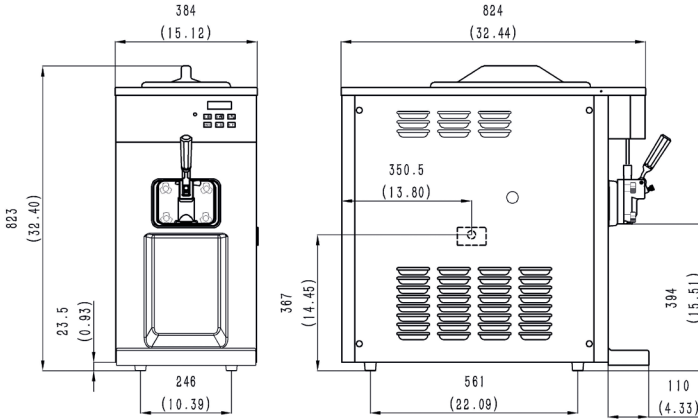

SPECIFICATIONS

Flavours	1
Freezing Cylinders	1 x 1.7L
Mix Hoppers	1 x 15L
Output Capacity (80 grams)	360 serves/hr
Clearance Requirements	152mm/6" on left

WEIGHT	KG/LB (Gravity)	KG/LB (Pump)
Net	120	NA
Shipping	NA	NA
Volume	0.40 CBM / 13.85 CBF	

DIMENSIONS	NET (MM/IN)	SHIPPING (MM/IN)
Width	384	500
Depth	824	870
Height	823	1080

ELECTRICAL	AMP	VOLT	POWER(KW)
Single Phase 16 AMP			

FEATURES

CONTROL SYSTEMS	SINGLE, DIGITAL
REFRIGERATED HOPPERS	✓
HOPPER AGITATOR OPTIONAL	✓
TEMPERATURE DISPLAY	✓
STANDBY MODE	✓
AUTO CLOSING DISPENSING VALVES	✓
DISPENSING SPEED CONTROL	✓
LOW MIX INDICATOR LIGHT	✓
LOW MIX INDICATOR ALARM	✓
LOW TEMPERATURE PROTECTION	✓
MOTOR AMPERAGE PROTECTION	✓
HIGH PRESSURE PROTECTION	✓
SOFT START	✓

BLUE ICE MACHINES LTD

Lea Road trading Estate, Lea Rd, Waltham Cross, London, Waltham Abbey EN9 1AE

020 8801 6919

info@blueicecreammachine.co.uk
www.blueicecreammachine.co.uk