

## MODEL T516-3

### FROZEN CARBONATED SLUSH MACHINES



**Extremely high output**, triple flavour carbonated frozen slush machine.



#### CARBONATION

Inline Carbonation™ – creates a more consistent over-run, quality, and yield.



#### DIGITAL CONTROL AND DISPLAY

Electronic simplicity offers easy-to-use keypad interface.



#### FLEXIBLE PLACEMENT

Optimal use of counter space with minimum ventilation of two inches on the sides and back.



#### FLAVOUR OPTIONS

Customizable individual barrels allow for hundreds of different drink profile combinations, including sugar-free options.



#### LOW OPERATING COST

Highest output and most cost-effective carbonated beverage dispenser on the market.



#### FOOTFALL

Ideal for extremely high volume locations with limited space

#### OPTIONAL ACCESSORIES



Base Cart with Casters



Painted Sheet Metal



Install Kit



Leg Kit (set of four)



BIB Rack

**THE INDUSTRY'S #1 MOST PROFITABLE AND TRUSTED  
CARBONATED SLUSH DISPENSERS**

**MAXIMISE YOUR PROFITS**

**MODEL T516-3**

FROZEN CARBONATED SLUSH MACHINES

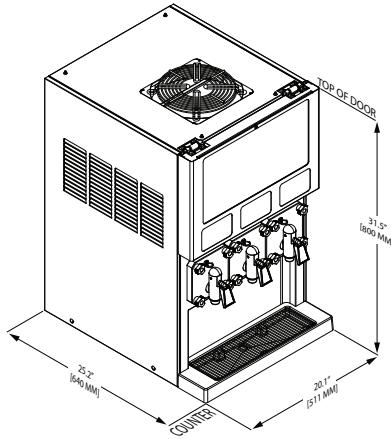

**CAPACITY**

Dispenser Type	Air-Cooled   Remote   Water-Cooled
Barrels	3x 176 oz
Clearance Requirements	Sides and Back: 3 in. (51 mm) Minimum. Top: 12 in. (305 mm) Minimum (from unit top panel)
Output Capacity	516 (10oz) cups /hr

**WATER, CO2 AND SYRUP REQUIREMENTS**

Water System Input	3/8" Sply Line, 30 PSIG Flow (min)
CO2 System Input	70 - 72 PSIG (maximum)
Syrup	Input: 70 - 72 PSIG (482-496 kPag) Bag-In-Box (BIB) Connections, (3) Base Syrups

**WEIGHT**

Empty Unit	163kg
------------	-------

**DIMENSIONS**

	NET (IN/MM)	SHIPPING (MM/IN)
Width	20.3in	NA
Depth	32.5 in	NA
Height:	short door 34in	
	tall door 41.4in	

**ELECTRICAL**

	AMP	VOLTS	POWER(KW)
Single phase	16	NA	NA

**FEATURES**

- ✓ MANUFACTURED TO THE HIGHEST SPECS FOR RETAILERS WITH STEADY FOOT TRAFFIC WHO NEED TO GENERATE HIGH MARGINS WITH MINIMAL COUNTER SPACE
- ✓ SMALLEST FOOTPRINT IN THE INDUSTRY WITH ENOUGH CAPACITY TO ENSURE YOU HAVE PLENTY PRODUCT TO HANDLE THOSE BUSY TIMES.
- ✓ DESIGNED WITH INNOVATIONS TO ALLOW EASY ACCESSIBILITY TO MAXIMISE UPTIME.
- ✓ COMPETITIVELY PRICES TO ALLOW OWNERSHIP AND TRANSPARENCY OF COSTINGS
- ✓ PROFIT DRIVER IN ALL HOSPITALITY SECTORS INCLUDING LEISURE, EDUCATIONAL, CONVENIENCE, RETAIL, RESTAURANTS, COFFEE SHOPS, FAST FOOD, PUBS & BARS