



Special Installation



Site Survey



# Slimline Serve Over Counter Tavira II Curved Range

## Features and Benefits

- Fully automatic. Static cooled
- Interior light with switch
- Digital controller and temp display
- Hinged glass for easy cleaning
- Ambient shelf
- Acrylic sliding doors to display area
- Hinged door to refrigerated understorage
- 13 Amp socket to rear for scales/till etc.
- Stainless rear shelf & deck
- Slide out refrigeration unit for easy servicing
- Number of storage doors: 1

## Technical Specifications

Temperature Range	+2/+5°C
Refrigerant	R134a
Type of Defrost	Off Cycle
Power Required	13 Amp
Max Ambient	25°C at 60% RH

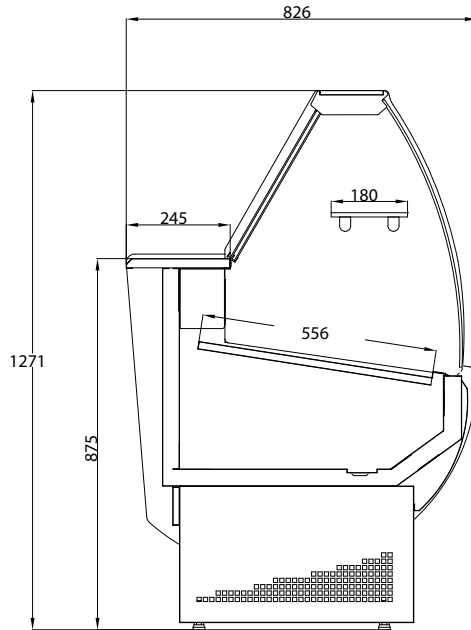

Model	Description	Ext.	Dimensions (mm)			Kg	List Price	Next Day
			H	W	D			
TAVIRA II 100C	White	Ext.	1271	980	826	112	£1,386	✓
TAVIRA II 130C	White	Ext.	1271	1280	826	160	£1,594	✓
TAVIRA II 150C	White	Ext.	1271	1480	826	205	£1,780	✓