

152

Soft serve freezer

Single flavour, Taylormate®



Features

Offer all of the popular soft serve variations from low or non-fat ice creams to custards, frozen yogurts and sorbet.

Freezing cylinder

One, 1.4 litre

Hourly production* (approximately)

12.2 litres per hour

Mix hopper

One, 7.6 litre. Separate hopper refrigeration to maintains the mix below 5°C during Auto and Standby modes.

Indicator light

'Mix Low' light alerts the operator to add mix.

Solid state controls

Taylor Quality Control precisely monitors viscosity to maintain consistent quality.

Standby

During long no-use periods, the standby feature maintains safe product temperatures in the mix hopper and freezing cylinder.

*Hourly output figures are based on machines operating in the optimum working environment and may vary depending on your operational circumstances.

Continuing research results in steady improvements; therefore, these specifications are subject to change without notice.

May 2014

TaylorUK
Soft Serve & Frozen Beverage Equipment

Taylor Company UK

106 Claydon Business Park, Ipswich, Suffolk, IP6 0NL

Tel: +44 (0) 1473 350000

Fax: +44 (0) 1473 350001

www.taylor-company.co.uk

ISO 9001:2008
Registered Firm

152 Soft serve freezer

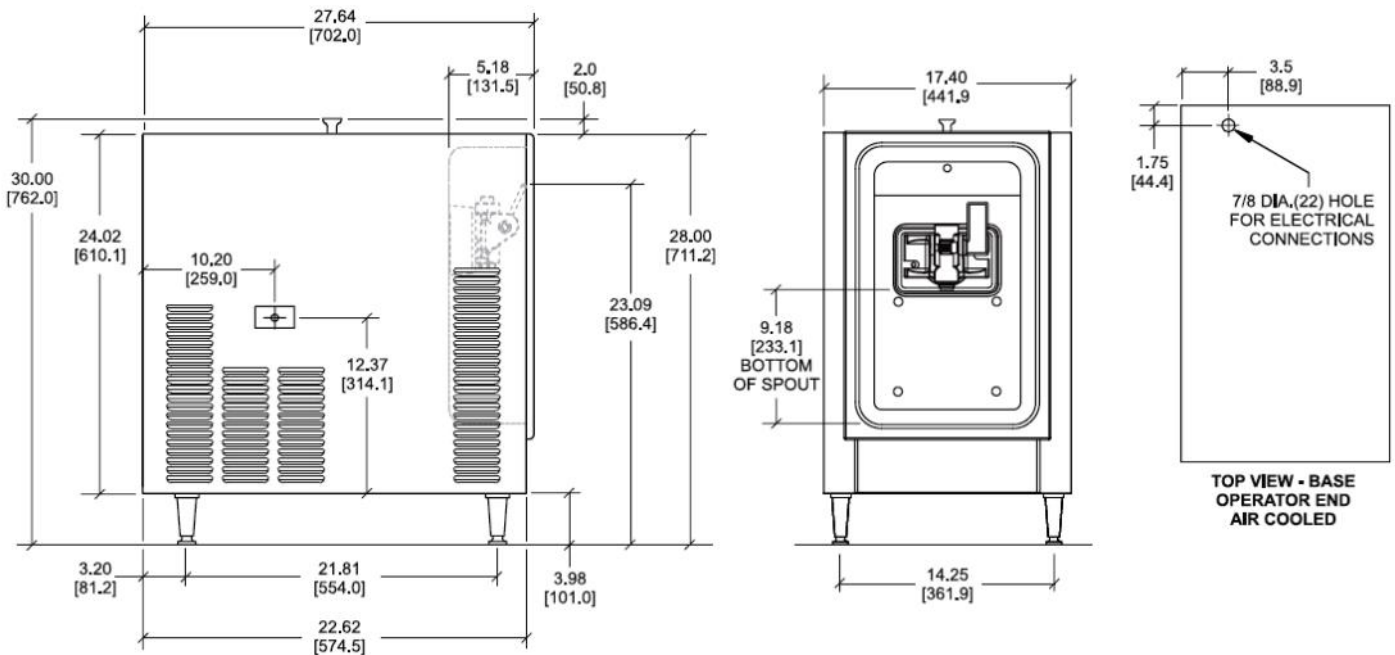

Figures in brackets indicate millimetres

| DIMENSIONS | | |
|--------------------------------------|--------------|--------|
| Height | 30" | 711 mm |
| Width | 17.44" | 442 mm |
| Depth | 27.69" | 702 mm |
| Counter clearance* | 4" | 102 mm |
| *Mounted on standard legs | | |
| Weight | 212 lbs. | 96 Kg |
| Wall air clearance (minimum)* | | |
| Back | - | - |
| Sides | 6" | 152 mm |
| Technical specification | | |
| Beater motor | 0.5 HP | |
| Refrigeration (freezer) | 3,000 BTU/hr | R404A |
| Refrigeration (hopper) | 400 BTU/hr | R134a |

The Taylor 152 is ONLY available AIR cooled.

*Minimum air clearances **MUST** be met to assure adequate airflow for optimum performance of air cooled machines. Install the skirt provided on the right side of the unit and place the back of the unit against a wall to prevent recirculation of warm air.

| ELECTRICAL SPECIFICATION - SINGLE PHASE | | |
|---|-------------------------|--|
| Taylor 152 | | |
| Voltage | 230 VAC | |
| Frequency | 50 Hz | |
| Circuit breaker | 13 amp fuse | |
| Plug/Socket | 13 amp dedicated socket | |

Optional extras

- Cone dispenser



Standard 6



LISTED
SA2650



Selected 50
Hz. Models

Continuing research results in steady improvements; therefore, these specifications are subject to change without notice.

May 2014

Taylor_{UK}
Soft Serve & Frozen Beverage Equipment

Taylor Company UK

106 Claydon Business Park, Ipswich, Suffolk, IP6 0NL

Tel: +44 (0) 1473 350000

Fax: +44 (0) 1473 350001

www.taylor-company.co.uk