

Tumble dryer

TD6-7 with heat pump



Dryer featuring exceptional savings and effortless use



Priority on people

Certified ergonomic design with a human-centered approach for an outstanding user experience

- Lint filter
The horizontal filter drawer is positioned for easy access and cleaning without the need to bend down when stacked on a WH6-6
- The display can easily be moved to the bottom of the tumble dryer for a better position when stacked



Long-term savings

Innovative features to save money and time, and embrace a sustainable lifestyle with up to 65% energy saving due to the heat pump technology

- Moisture Balance
Helps to stop the drying process at the right time to save on energy costs



Pure control

Monitor your equipment and performance from anywhere, allowing to take action and to improve your business with OnE Laundry - the personal assistant for hygiene validation management, process management and revenue management (optional)



Outstanding productivity

Dry more laundry in less time: a game-changing improvement

- Reversing drum
Minimizes wrinkles and drying time to get an effective and even drying performance

Main options and accessories

- Insulated glass door keeps the door cool on the outside and heat on the inside, so the room temperature is not affected
- Lagoon Advanced Care
- Door, front and side panels are available in stainless steel
- Connectable to booking-/payment system or coin meter



Images shown are a representation of the product only and variations may occur.
To get the door design you need to add the insulated glass.

Main specifications		TD6-7
Rated capacity, filling factor 1:18	kg/lb	7.5/16.5
filling factor 1:22	kg/lb	6.1/13.4
Drum volume	litre	135
Drum diameter	mm	575
Rated input	kW	2.3
Consumption data*		
Total time full load	min	42
Energy consumption full load	kWh	1.28
Evaporation	g/min	73
Energy kWh/litre water evaporated	kWh/l	0.42

* At rated capacity 1:22, 100% cotton load at 50% initial moisture dried to 0%.

Produced according to ISO 9001 and ISO 14001.

Certified with CB certificate for Low Voltage Directive and S-mark according to the Machinery Directive. Protection class IP X4D.

Electrical connections					
Heating alternative	Main voltage		Heating power kW	Total power kW	Recommended fuse A
	Hz				
Heat pump	220-240V 1/1N 3 - 50/60		*	2.3	10
	380-415V 3N - 50/60				

* Total power and recommended fuse does not depend on the heating power in those cases.

Sound levels		TD6-7
Sound power/pressure level at drying*		
	dB(A)	63/48
Heat emission		
% of installed power, max		15
Shipping data**		
Weight	kg	131
Shipping volume	crated, m ³	0.81
Dimensions in mm		
A	Width	600
B	Depth	845
C	Height	1050
D		582
E		384
F		296
G		79
H		75
I		211
J		50
1	Operating panel	
2	Door opening \varnothing 392 mm	
3	Electrical connection	
4	Drain for condense water	

* Sound power levels measured according to ISO 60704.

** Average data. Crated weight/shipping volume depends on configuration. Please contact logistics for exact measures.

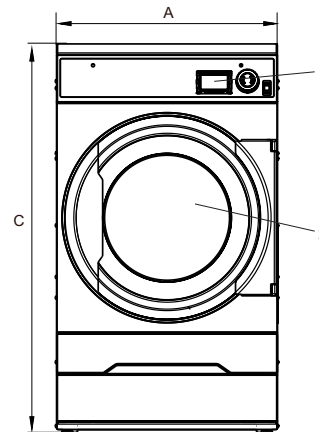

Front

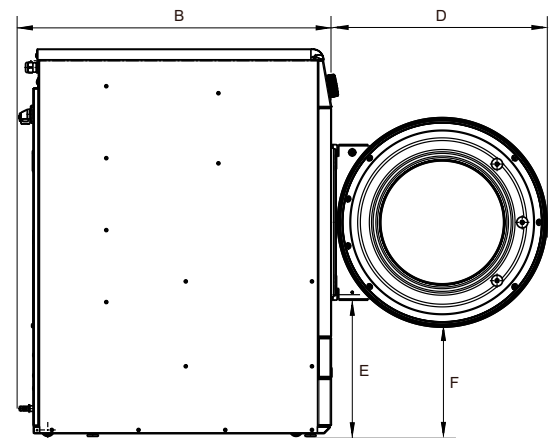

Left side

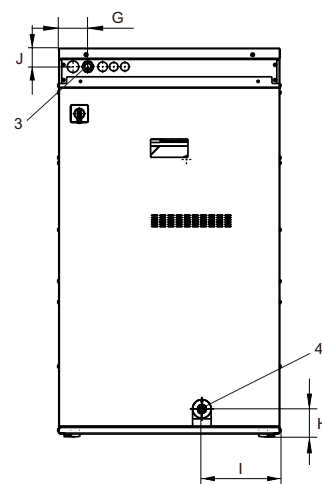

Rear side