

Toucan

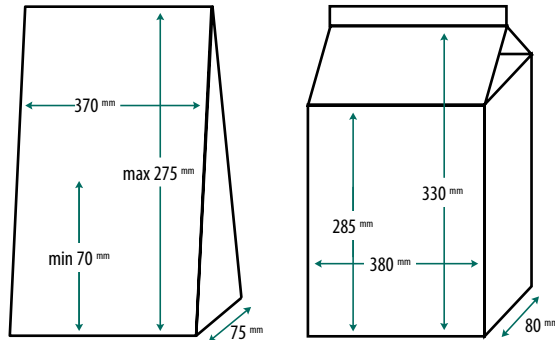

Series of vertical vacuum packaging machines, suitable for packing pouches of different sizes through the adjustable platform provided. Unique table-top models to vacuum pack sauces, soups, coffee and powders in square or rectangular packages and pouches. Comes with a specially made to measure mould for easy and custom vertical packing of your products.



TOUCAN REGULAR



STANDARD

TIME CONTROL, DOUBLE/
WIDE SEAL, SOFT AIR

OPTIONS

SENSOR CONTROL, ACS,
LIQUID CONTROL, GAS FLUSH,
BI-ACTIVE SEAL

INCLUDING

PLATFORM FOR STAND-UP
POUCHES (SELF-STANDING)

PUMP CAPACITY 21 m³/h
MACHINE CYCLE 15-35 sec
MACHINE DIMENSIONS
480 x 490 x 780 mm
SEAL BAR 420 mm
WEIGHT 79 kg
VOLTAGE 230V-1-50Hz
POWER 0,75 kW

TOUCAN SQUARE



STANDARD

TIME CONTROL, DOUBLE SEAL,
SOFT AIR

OPTIONS

SENSOR CONTROL, ACS,
LIQUID CONTROL, GAS FLUSH,
BI-ACTIVE SEAL

INCLUDING

MOULD FOR SQUARE PACKAGES,
PLATFORM FOR STAND-UP
POUCHES (SELF-STANDING)

PUMP CAPACITY 21 m³/h
MACHINE CYCLE 15-35 sec
MACHINE DIMENSIONS
480 x 490 x 780 mm
SEAL BAR 420 mm
WEIGHT 79 kg
VOLTAGE 230V-1-50Hz
POWER 0,75 kW

The chamber dimensions listed refer to the usable space in the vacuum chamber (length x width x height).
The machine dimensions listed refer to length x width x height. Other voltages available. Textual and printing errors reserved.