



IMMERSION BLENDER XM-51 230/50-60/1

Professional immersion blender. 570 W.



3030820



INCLUDES

- ✓ Fixed speed motor block.
- ✓ MA-51 mixer arm.
- ✓ Wall mount.

OPTIONAL

- MA-52 mixer arm.

ACCESSORIES

- Clamp sliding frame
- Bowl clamp
- Mixer arms MA-50
- "Quick fix" Bowl clamp

SPECIFICATIONS

Total loading: 570 W
Maximum recipient capacity: 80 l
Maximum working depth: 283.3 mm
Motor speed: 12000 rpm
Blade diameter: 60 mm
Blade guard diameter: 101 mm
Electrical supply: 230 V / 50-60 Hz / 1 ~ (3.2 A)
Plug: UK (BS 1363 10A / 2P)

Length

Liquidising arm length: 425 mm
Total length: 765 mm
Net weight: 4.79 Kg
Noise level (1m.): <80 dB(A)

Crated dimensions

575 x 455 x 130 mm
Gross weight: 5.94 Kg

SALES DESCRIPTION

- ✓ Fixed speed motor block.
- ✓ 425 mm detachable arm.
- ✓ Designed for continuous use in recipients of up to 80 l.

All-in-one

- ✓ Professional hand blender designed for carrying out different preparations without the need for add-on tools.
- ✓ Professional Y-blade, made from tempered steel and with a long-duration cutting edge.
- ✓ Fixed speed.
- ✓ Designed to work in recipients of up to 80 litres.

Maximum comfort for the user

- ✓ Logical and manageable size.
- ✓ Ergo-design & bi-mat-grip: external casing made in two materials for an ergonomic hold. Anti-slip grip. Optimum inclination of handle, minimising fatigue.
- ✓ Click-on-arm: detachable arm with fast and secure closure.
- ✓ Hood designed to avoid splashes.
- ✓ Intuitive use: very simple operation. LED warning light in two colours to indicate the status of the machine.
- ✓ Possibility of continuous operation.

Built to last

- ✓ Professional performance: capable of carrying out prolonged work without the casing overheating.
- ✓ Life-plus: equipped with a motor which has passed all of the most demanding usage tests.
- ✓ Studied geometry: casing designed to avoid rolling and falling.
- ✓ Easy to clean: detachable arm, can be cleaned under the tap.
- ✓ Approved by NSF: guaranteed safety and hygiene.

DYNAMIC PREPARATION
COMMERCIAL HAND BLENDERS

product sheet
updated 21/04/2022



SAMMIC, S.L.
Bassate, 1 - 20729 Azzola
www.sammic.com



IMMERSION BLENDER XM-51 230/50-60/1

Professional immersion blender. 570 W.



3030820

DYNAMIC PREPARATION
COMMERCIAL HAND BLENDERS

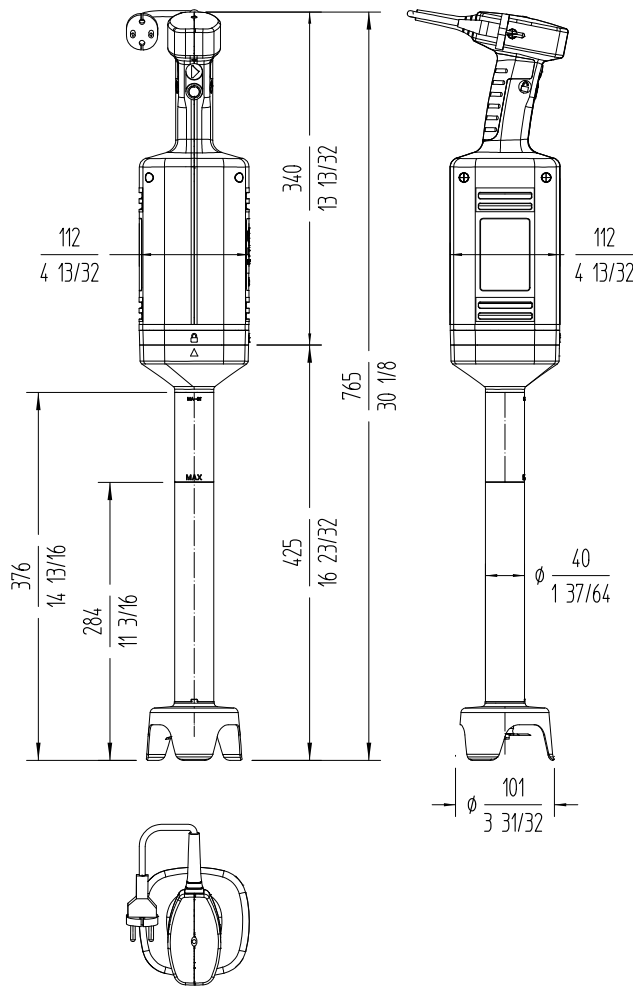

www.sammic.co.uk

Food Service Equipment Manufacturer

Unit 2, Trevanth Road
Troon Industrial Park
LE4 9LS - Leicester

uksales@sammic.com
Tel.: +44 0116 246 1900

Project	Date
Item	Qty
Approved	

product sheet updated 21/04/2022