



IMMERSION BLENDER XM-31 230/50-60/1

Professional immersion blender. 400 W.



3030672



INCLUDES

- ✓ Fixed speed motor block.
- ✓ MA-31 mixer arm.
- ✓ Wall mount.

OPTIONAL

- MA-32 mixer arm.
- MA-33 mixer arm.

ACCESSORIES

- Clamp sliding frame
- Bowl clamp
- Mixer arms MA-30
- "Quick fix" Bowl clamp

SPECIFICATIONS

Total loading: 400 W
 Maximum recipient capacity: 30 l
 Motor speed: 12000 rpm
 Blade guard diameter: 92.2 mm
 Electrical supply: 230 V / 50-60 Hz / 1 ~ (1.7 A)
 Plug: EU (SCHUKO 2P)

Length

Liquidising arm length: 306 mm
 Total length: 614 mm
 Net weight: 3.34 Kg
 Noise level (1m.): <80 dB(A)

Crated dimensions

455 x 475 x 117 mm
 Gross weight: 4.2 Kg

SALES DESCRIPTION

- ✓ Fixed speed motor block.
- ✓ 306 mm detachable arm.
- ✓ Designed for continuous use in recipients of up to 30 l.

All-in-one

- ✓ Professional hand blender designed for carrying out different preparations without the need for add-on tools.
- ✓ Professional Y-blade, made from tempered steel and with a long-duration cutting edge.
- ✓ Fixed speed.
- ✓ Designed to work in recipients of up to 30 litres.

Maximum comfort for the user

- ✓ Compact design: logical and manageable size.
- ✓ Ergo-design & bi-mat-grip: external casing made in two materials for an ergonomic hold. Anti-slip grip. Optimum inclination of handle, minimising fatigue.
- ✓ Click-on-arm: detachable arm with fast and secure closure.
- ✓ Hood designed to avoid splashes.
- ✓ Intuitive use: very simple operation. LED warning light in two colours to indicate the status of the machine.
- ✓ Possibility of continuous operation.

Built to last

- ✓ Professional performance: capable of carrying out prolonged work without the casing overheating.
- ✓ Life-plus: equipped with a motor which has passed all of the most demanding usage tests.
- ✓ Studied geometry: casing designed to avoid rolling and falling.
- ✓ Easy to clean: detachable arm, can be cleaned under the tap.
- ✓ Approved by NSF: guaranteed safety and hygiene.

DYNAMIC PREPARATION
COMMERCIAL HAND BLENDERS

product sheet
updated 21/04/2022



SAMMIC, S.L.
Bassaré, 1 - 20720 Azzovita
www.sammic.com



IMMERSION BLENDER XM-31 230/50-60/1

Professional immersion blender. 400 W.



3030672

DYNAMIC PREPARATION
COMMERCIAL HAND BLENDERS

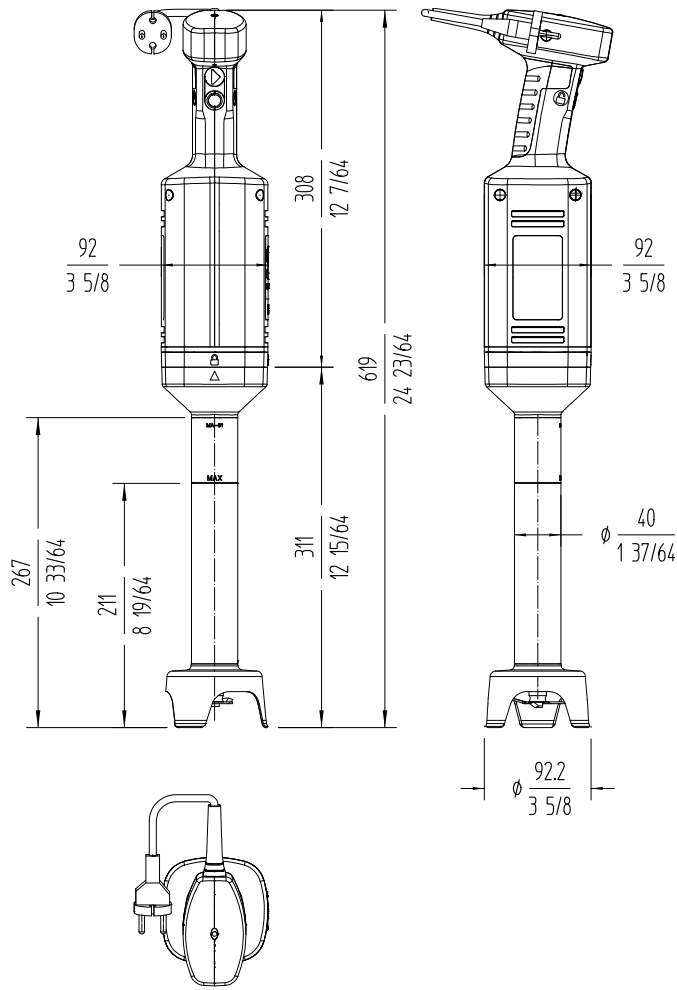

www.sammic.co.uk
 Food Service Equipment Manufacturer
 Unit 2, Trevanth Road
 Troon Industrial Park
 LE4 9LS - Leicester
 uksales@sammic.com
 Tel.: +44 0116 246 1900



Project	Date
Item	Qty
Approved	

product sheet
updated 21/04/2022