

MODELS: UC27R UC60R UC48R UC72R **AMERICAN LINE: Undercounter Refrigerators**



UC 27 R



UC 48 R



UC 72 R

General Strengths

- ✓ *Doors are equipped with hinges for automatic return and permanent pressure during closing. The automatic return is free when the opening exceeds 95°. Includes "three-chamber door gasket easily removable. Doors are reversible.*
- ✓ *The control system has a greater precision in the control of the temperature. Easier to adjust the temperature range we want to achieve.*
- ✓ *All condenser units are tested 100%, in helium chambers to refrigerant leak detections.*
- ✓ *Infrico is AENOR audited and certified by internationally recognized firm. ISO 9001:2015 (Quality); ISO 14001:2015 (Environmental); OSHAS 18001:2007 (Prevention and Worker Safety). Audited and Certified by INTERTEK for compliance with UL 471 and NSF 7.*

MODELS	Dimensions (mm)			Nº Doors	Nº Shelves/slides	Chamber Volume (L)	Gross Volume (L)	Temperature regime (°C)	Ref.	Gas charge (gr.)	Net Weight (Kg.)
	Length	Depth	Height								
UC27R	702	766	908	1	2/2	200	490	-2 °C / +8°C	R134a	260	83
UC48R	1227	766	908	2	4/4	380	855	-2 °C / +8°C	R134a	280	120
UC60R	1533	766	908	2	4/4	480	1070	-2 °C / +8°C	R134a	280	163
UC72R	1844	766	908	3	6/6	590	1285	-2 °C / +8°C	R134a	320	176

WE RESERVE THE RIGHT TO CHANGE SPECIFICATIONS WITHOUT PRIOR NOTICE



Infrico
 Ctra. de Aguilar A-318 por Moriles
 km.15,5 - A-3132
 14900 Lucena (Córdoba)
 Spain

www.infrico.com
 info@infrico.com
 Tel. 00 34 957 51 03 03
 Fax. 00 34 957 51 03 04

APPROVALS: AVAILABLE AT:



MODELS: UC27R UC48R	UC60R UC72R	AMERICAN LINE: Undercounter Refrigerators
-------------------------------	----------------	--

STANDARD FEATURES

➤ Exterior

- AISI 304 Series Stainless Steel worktop and sides AISI 430 Stainless Steel.
- Completely injected compact structure,
- Casters, 100 mm diameter casters. Breaks provided on front set.

➤ Interior

- AISI 430 Stainless Steel.

➤ Insulation

- Insulation by free CFC's polyurethane foam high-pressure injected with density 40 Kg/m³,
- Zero ODP and Low GWP.

➤ Doors

- Doors with integrated handle and blocked opening hinge.
- Interior of door inserted with a triple chamber door gasket easy to remove.
- Possibility of changing the opening sense of the doors.
- Door opening WxH: 590x554 mm (UC27R), 498x554 mm (UC48R/UC72R), 650x554 mm (UC60R).

➤ Shelves

- Plastic coated wire shelves and stainless steel shelf brackets.
- (2) interior shelves per door and a set of brackets per shelf, included.
- Guides and shelves easy to take off for cleaning.
- Dimensions: WxD: 570x437 mm (UC27R), 540x437 mm (UC48R/UC72R), 693x437 mm (UC60R).

➤ Refrigeration

- Temperature regulated by a thermostatic controller.
- Automatic defrost.
- System of ventilated condensation.
- System of Forced Evaporation.
- Evaporative pan.
- Evaporator coil coated with anti-corrosion material.
- Front-breathing refrigeration system.
- Climatic class 4 (30°C, 55%RH).

➤ Electrical

- Electrical connection: 220 V / 1 ph / 50 Hz. 

OPTIONAL

- Worktop with sanitary backsplash of 100 mm height,

- Electrical connection 220 V / 1 ph / 60 Hz.,
- Electrical connection 115 V / 1 ph / 60 Hz.

MODELS	Dimensions Palletizing (mm)			Crated Weight (Kg.)	Power (W)	Comp. (HP)	Cooling Power (W at -10°C)	Cons. (kWh/24h)	Inten. (A)	Container 20'/40'/40'HC	Trailer
	Length	Depth	Height								
UC27R	800	880	1000	92	381	1/5	254	2,98	2,0	28 / 56 / 56	90
UC48R	1340	880	1000	160	538	1/4	298	3,69	2,6	20 / 42 / 42	50
UC60R	1650	880	1000	195	577	1/4	298	3,87	2,7	14 / 28 / 28	32
UC72R	1950	880	1000	229	743	3/8	464	4,63	3,1	12 / 26 / 26	30

WE RESERVE THE RIGHT TO CHANGE SPECIFICATIONS WITHOUT PRIOR NOTICE

MODELS: UC27R UC60R UC48R UC72R **AMERICAN LINE: Undercounter Refrigerators**

GENERAL VIEW

FRONT VIEW

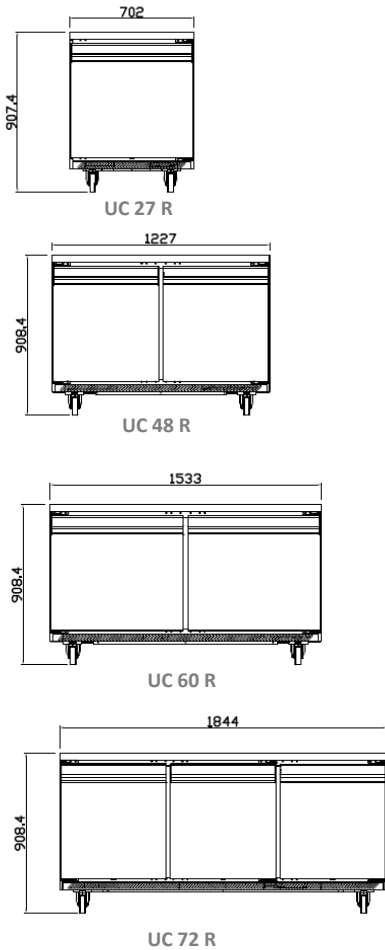

TOP VIEW

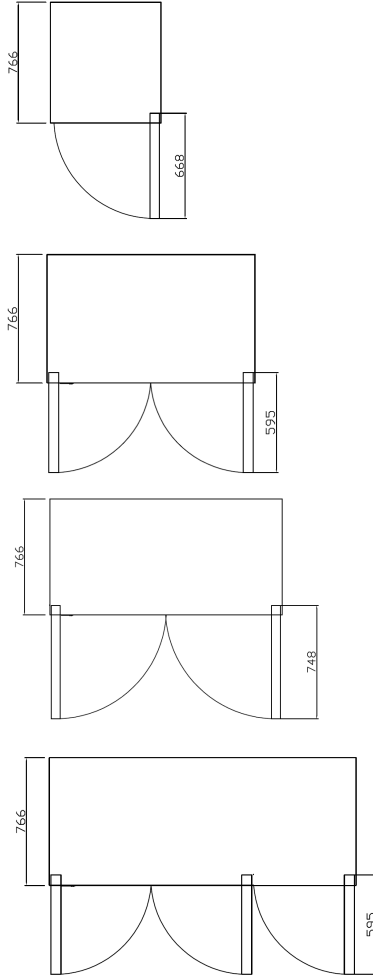

SIDE VIEW

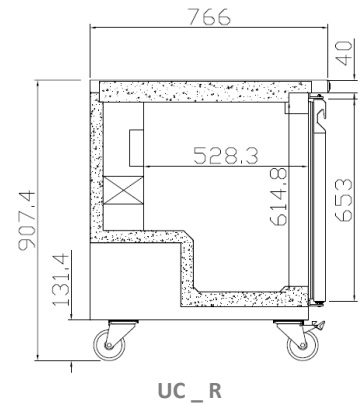

CONNECTIONS

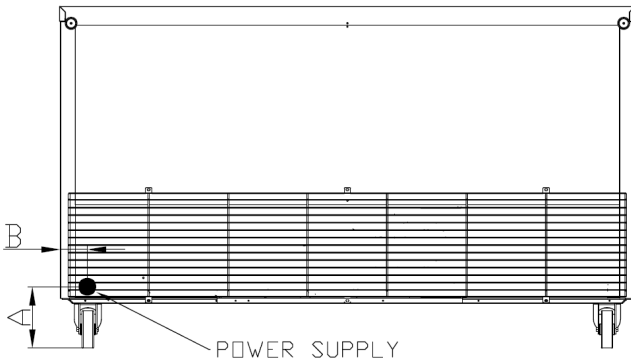

MODELS	A (mm)	B (mm)
UC27R	180	55
UC48R	180	55
UC60R	180	55
UC72R	180	55

WE RESERVE THE RIGHT TO CHANGE SPECIFICATIONS WITHOUT PRIOR NOTICE



Infrico
 Ctra. de Aguilar A-318 por Moriles
 km.15,5 - A-3132
 14900 Lucena (Córdoba)
 Spain

www.infrico.com
info@infrico.com
 Tel. 00 34 957 51 03 03
 Fax. 00 34 957 51 03 04

APPROVALS: _____ AVAILABLE AT: _____

