

# Ventus Bottle coolers



*Technical Information*  
*Ventus Bottle coolers*

***imc***



## overview

Ventus bottle coolers are available in single and double door versions, with a choice of stainless steel, polished stainless steel or black, brown or silver painted finishes. Each unit comes with adjustable shelving, temperature display and internal light as standard. The cabinets come in a variety of sizes with standard versions, a shallow version, and two short size versions.

Features include electronic controller with auto defrost and Dynamic Air Distribution System (DADS) and, for greater energy efficiency, the eco smart system is fitted as standard to all coolers. A robust construction ensures long term reliability and low operating costs.

### **Additional features include:**

- Replaceable door seal for easy cleaning and increased product life span
- CFC-free and ozone friendly
- Ventilation to front of cabinet ensuring units can be fully built in
- Can be installed side by side with no gaps

### **Standard Models**

V60 Single hinged door

V90 Double hinged door

### **Options**

Refer to options sheet at rear of document.

## product conformity

Ventus bottle coolers are manufactured in accordance with the following European Directives:

Machinery Directive (2006/42/EC)

Low Voltage Directive (2006/95/EC)

Electromagnetic Compatibility Directive (2004/108/EC)

Pressure Equipment Directive (97/23/EC)

And in accordance with the following harmonised

European Standards:

EN61000-6-3: 2001 Emissions and EN61000-6-1: 2001 Immunity

(plus product specific standards)

BS EN 60335-1 and BS EN 60335-24

## ventus V60

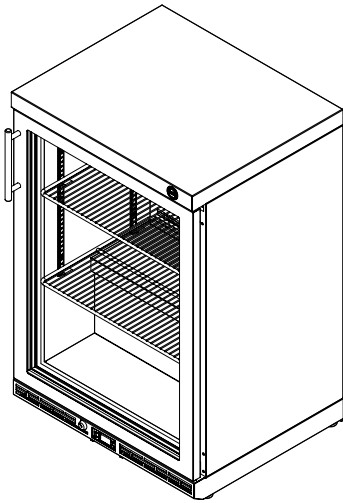

<b>Storage Capacity</b>			
330ml Bottles	120		
<b>Operating Temperature</b>			
Internal Operating Temperature	(°C)+4(+/-2)		
<b>Shipping Specifications</b>			
Weight (kg) (Net)	57.5		
Weight (kg) (Gross)	64		
Packing Size (mm) (h <sup>x</sup> w <sup>x</sup> d)	970 x 665 x 580		
Packing Volume (m <sup>3</sup> )	0.37		
<b>Electrical Information</b>			
Voltage (Volts)	230	115	220
Frequency (Hz)	50	60	60
Phase	single		
Current Draw (Amps)	1.9		
<b>Maximum Dimensions</b>			
	Internal	External	
Height (mm)	754	900	
Width (mm)	526	600	
Depth (mm)	376	500	
<b>Product Code Detail</b>			
F76/100	V60 Stainless steel		
F76/100 P	V60 Stainless steel (polished)		
F76/100 BL	V60 Black		
F76/100 BR	V60 Brown		
F76/100 SL	V60 Silver		

## ventus V90

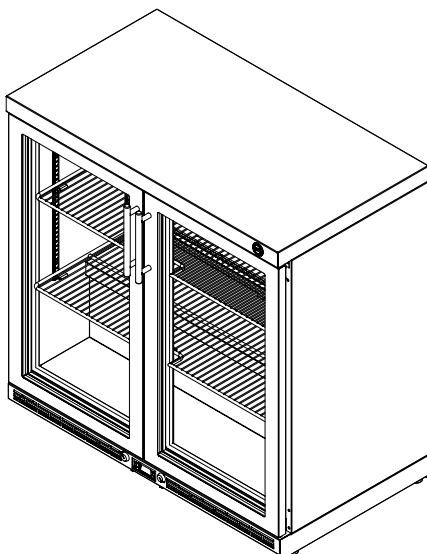

<b>Storage Capacity</b>			
330ml Bottles	195		
<b>Operating Temperature</b>			
Internal Operating Temperature	(°C)+4(+/-2)		
<b>Shipping Specifications</b>			
Weight (kg) (Net)	76.5		
Weight (kg) (Gross)	85		
Packing Size (mm) (h <sup>x</sup> w <sup>x</sup> d)	970 x 965 x 580		
Packing Volume (m <sup>3</sup> )	0.55		
<b>Electrical Information</b>			
Voltage (Volts)	230	115	220
Frequency (Hz)	50	60	60
Phase	single		
Current Draw (Amps)	2.0		
<b>Maximum Dimensions</b>			
	Internal	External	
Height (mm)	754	900	
Width (mm)	826	900	
Depth (mm)	376	500	
<b>Product Code Detail</b>			
F76/200	V90 Stainless steel		
F76/200 P	V90 Stainless steel (polished)		
F76/200 BL	V90 Black		
F76/200 BR	V90 Brown		
F76/200 SL	V90 Silver		

<b>Storage Capacity</b>			
330ml Bottles	96		
<b>Operating Temperature</b>			
Internal Operating Temperature	(°C)+4(+/-2)		
<b>Shipping Specifications</b>			
Weight (kg) (Net)	56		
Weight (kg) (Gross)	62.7		
Packing Size (mm) (hwxwd)	970 x 665 x 580		
Packing Volume (m3)	0.37		
<b>Electrical Information</b>			
Voltage (Volts)	230	115	220
Frequency (Hz)	50	60	60
Phase	single		
Current Draw (Amps)	1.9		
<b>Maximum Dimensions</b>			
	<i>Internal</i>	<i>External</i>	
Height (mm)	754	900	
Width (mm)	526	600	
Depth (mm)	326	450	
<b>Product Code Detail</b>			
F76/103	V60 Stainless steel		
F76/103 P	V60 Stainless steel (polished)		
F76/103 BL	V60 Black		
F76/103 BR	V60 Brown		
F76/103 SL	V60 Silver		

## ventus V60 shallow

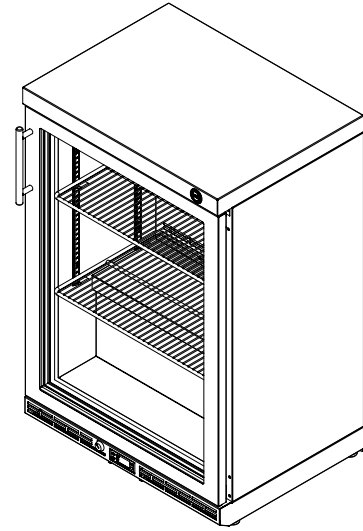

<b>Storage Capacity</b>			
330ml Bottles	156		
<b>Operating Temperature</b>			
Internal Operating Temperature	(°C)+4(+/-2)		
<b>Shipping Specifications</b>			
Weight (kg) (Net)	75		
Weight (kg) (Gross)	83.5		
Packing Size (mm) (hwxwd)	970 x 965 x 580		
Packing Volume (m3)	0.55		
<b>Electrical Information</b>			
Voltage (Volts)	230	115	220
Frequency (Hz)	50	60	60
Phase	single		
Current Draw (Amps)	2.0		
<b>Maximum Dimensions</b>			
	<i>Internal</i>	<i>External</i>	
Height (mm)	754	900	
Width (mm)	826	900	
Depth (mm)	326	450	
<b>Product Code Detail</b>			
F76/203	V90 Stainless steel		
F76/203 P	V90 Stainless steel (polished)		
F76/203 BL	V90 Black		
F76/203 BR	V90 Brown		
F76/203 SL	V90 Silver		

## ventus V90 shallow

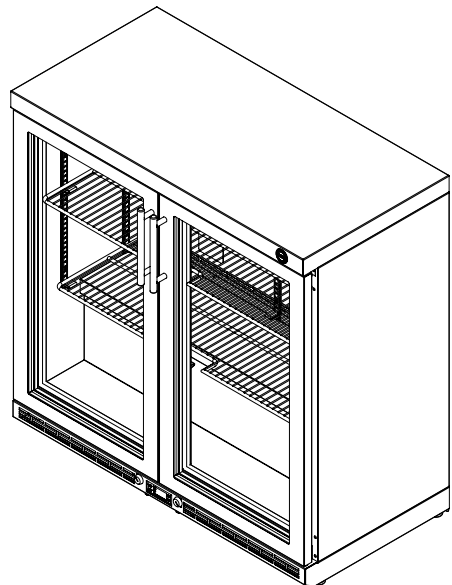

## ventus V60 Short 850

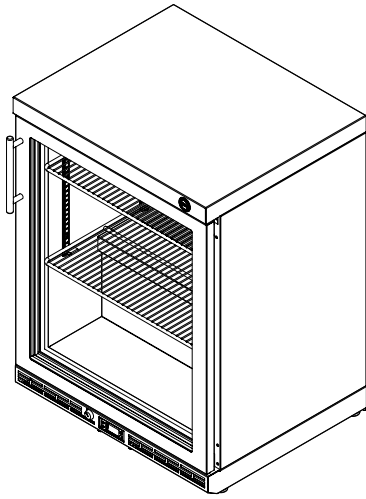

<b>Storage Capacity</b>			
330ml Bottles	72 + 48 (150ml cans)		
<b>Operating Temperature</b>			
Internal Operating Temperature	°C)+4(+/-2)		
<b>Shipping Specifications</b>			
Weight (kg) (Net)	56.3		
Weight (kg) (Gross)	63		
Packing Size (mm) (h <sub>x</sub> w <sub>x</sub> d)	970 x 665 x 580		
Packing Volume (m <sup>3</sup> )	0.37		
<b>Electrical Information</b>			
Voltage (Volts)	230	115	220
Frequency (Hz)	50	60	60
Phase	single		
Current Draw (Amps)	1.9		
<b>Maximum Dimensions</b>			
	Internal	External	
Height (mm)	704	850	
Width (mm)	526	600	
Depth (mm)	376	500	
<b>Product Code Detail</b>			
F76/101	V60 Stainless steel		
F76/101 P	V60 Stainless steel (polished)		
F76/101 BL	V60 Black		
F76/101 BR	V60 Brown		
F76/101 SL	V60 Silver		

## ventus V90 Short 850

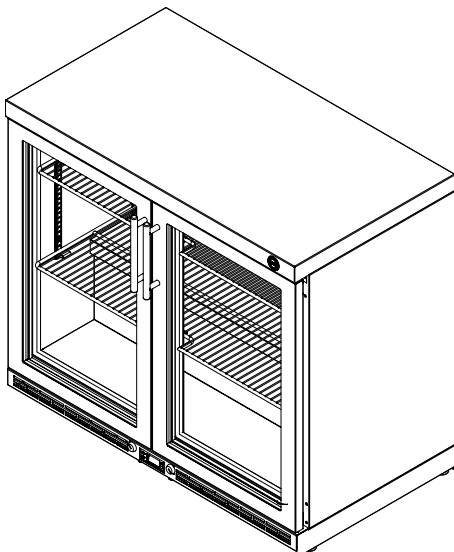

<b>Storage Capacity</b>			
330ml Bottles	117 + 78 (150ml cans)		
<b>Operating Temperature</b>			
Internal Operating Temperature	°C)+4(+/-2)		
<b>Shipping Specifications</b>			
Weight (kg) (Net)	74.8		
Weight (kg) (Gross)	83.3		
Packing Size (mm) (h <sub>x</sub> w <sub>x</sub> d)	970 x 965 x 580		
Packing Volume (m <sup>3</sup> )	0.55		
<b>Electrical Information</b>			
Voltage (Volts)	230	115	220
Frequency (Hz)	50	60	60
Phase	single		
Current Draw (Amps)	2.0		
<b>Maximum Dimensions</b>			
	Internal	External	
Height (mm)	704	850	
Width (mm)	826	900	
Depth (mm)	376	500	
<b>Product Code Detail</b>			
F76/201	V90 Stainless steel		
F76/201 P	V90 Stainless steel (polished)		
F76/201 BL	V90 Black		
F76/201 BR	V90 Brown		
F76/201 SL	V90 Silver		

## ventus V60 Short 800

Storage Capacity			
330ml Bottles	72 + 48 (150ml cans)		
Operating Temperature			
Internal Operating Temperature	(°C)+4(+/-2)		
Shipping Specifications			
Weight (kg) (Net)	55		
Weight (kg) (Gross)	61.5		
Packing Size (mm) (hxwxd)	970 x 665 x 580		
Packing Volume (m3)	0.37		
Electrical Information			
Voltage (Volts)	230	115	220
Frequency (Hz)	50	60	60
Phase	single		
Current Draw (Amps)	1.9		
Maximum Dimensions			
	Internal	External	
Height (mm)	654	800	
Width (mm)	526	600	
Depth (mm)	376	500	
Product Code Detail			
F76/102	V60 Stainless steel		
F76/102 P	V60 Stainless steel (polished)		
F76/102 BL	V60 Black		
F76/102 BR	V60 Brown		
F76/102 SL	V60 Silver		

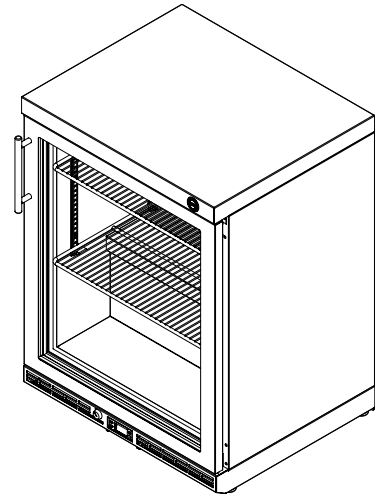

## ventus V90 Short 800

Storage Capacity			
330ml Bottles	117 + 78 (150ml cans)		
Operating Temperature			
Internal Operating Temperature	(°C)+4(+/-2)		
Shipping Specifications			
Weight (kg) (Net)	73		
Weight (kg) (Gross)	81.5		
Packing Size (mm) (hxwxd)	970 x 965 x 580		
Packing Volume (m3)	0.55		
Electrical Information			
Voltage (Volts)	230	115	220
Frequency (Hz)	50	60	60
Phase	single		
Current Draw (Amps)	2.0		
Maximum Dimensions			
	Internal	External	
Height (mm)	654	800	
Width (mm)	826	900	
Depth (mm)	376	500	
Product Code Detail			
F76/202	V90 Stainless steel		
F76/202 P	V90 Stainless steel (polished)		
F76/202 BL	V90 Black		
F76/202 BR	V90 Brown		
F76/202 SL	V90 Silver		

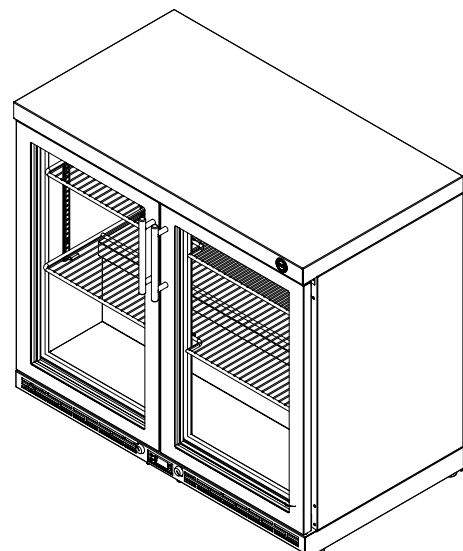

# V60 Options

Ventus V60 Range - Single Door Bottle Cooler					
		V60 - Standard	V60 - Short Cabinet - 850mm	V60 - Short Cabinet - 800mm	V60 - Shallow Cabinet 450mm
•	Standard Item				
○	Optional Item				
NA	Not available on this model				
<b>Dimensions</b>	Height	900	850	800	900
	Width	600	600	600	600
	Depth	500	500	500	450
<b>External Finish</b>	Black	•	•	•	•
	Silver	•	•	•	•
	Brown	•	•	•	•
	Stainless Steel	•	•	•	•
	Polished Stainless Steel	•	•	•	•
<b>Door Type</b>	Standard Standard handle only	•	•	•	•
	Standard Solid Door Standard handle only	○	○	○	○
	Frameless Door Standard Handle & Frameless Glass Only	○	NA	NA	○
	Fixing Point Door Add option handle below	○	○	○	○
	Fixing Point Solid Door Add option handle below	○	○	○	○
<b>Glass Option</b>	Standard Clear Glass	•	•	•	•
	Grey Tint Glass	○	○	○	○
	Bronze Tint Glass	○	○	○	○
	Opaque Glass	○	○	○	○
	Frameless Only Available with Frameless Door	○	NA	NA	○
<b>Door fixing</b>	Right hand	•	•	•	•
	Left hand	○	○	○	○
<b>Handle Type</b>	Standard Handle Included with Std, Solid & Frameless Doors	•	•	•	•
	Short Vertical To be ordered with fixing point door	○	○	○	○
	Short Horizontal To be ordered with fixing point door	○	○	○	○
	Long Vertical To be ordered with fixing point door	○	○	○	○
	Long Horizontal To be ordered with fixing point door	○	○	○	○
<b>Lighting</b>	Standard Fluorescent Not available with 115V Compressor	•	•	•	•
	White LED	○	○	○	○
	Blue LED	○	○	○	○
	Red LED	○	○	○	○
	Green LED	○	○	○	○
<b>Shelving</b>	Chrome Wire	•	•	•	•
	Chrome Wine Shelf	○	○	○	NA
	Steel Perforated Plate	○	○	○	○
<b>Electrical</b>	230 V / 50 Hz	•	•	•	•
	220 V / 60 Hz	○	○	○	○
	115 V / 60 Hz Includes LED lighting	○	○	○	○
<b>Plug</b>	UK (3 Pin) Plug	•	•	•	•
	EU Plug	○	○	○	○

# V90 Options

Ventus V90 Range - Double Door Bottle Cooler		V90 - Standard	V90 - Short Cabinet - 850mm	V90 - Short Cabinet - 800mm	V90 - Shallow Cabinet 450mm	
•	Standard Item					
○	Optional Item					
NA	Not available on this model					
<b>Dimensions</b>	Height	900	850	800	900	
	Width	900	900	900	900	
	Depth	500	500	500	450	
<b>External Finish</b>	Black	•	•	•	•	
	Silver	•	•	•	•	
	Brown	•	•	•	•	
	Stainless Steel	•	•	•	•	
	Polished Stainless Steel	•	•	•	•	
<b>Door Type</b>	Standard	Standard handle only	•	•	•	•
	Standard Solid Door	Standard handle only	○	○	○	○
	Frameless Door	Standard Handle & Frameless Glass Only	○	NA	NA	○
	Fixing Point Door	Add option handle below	○	○	○	○
	Fixing Point Solid Door	Add option handle below	○	○	○	○
<b>Glass Option</b>	Standard Clear Glass	•	•	•	•	
	Grey Tint Glass	○	○	○	○	
	Bronze Tint Glass	○	○	○	○	
	Opaque Glass	○	○	○	○	
	Frameless	Only Available with Frameless Door	○	NA	NA	○
<b>Handle Type</b>	Standard Handle	Included with Std, Solid & Frameless Doors	•	•	•	•
	Short Vertical	To be ordered with fixing point door	○	○	○	○
	Short Horizontal	To be ordered with fixing point door	○	○	○	○
	Long Vertical	To be ordered with fixing point door	○	○	○	○
	Long Horizontal	To be ordered with fixing point door	○	○	○	○
<b>Lighting</b>	Standard Fluorescent	Not available with 115V Compressor	•	•	•	•
	White LED		○	○	○	○
	Blue LED		○	○	○	○
	Red LED		○	○	○	○
	Green LED		○	○	○	○
<b>Shelving</b>	Chrome Wire		•	•	•	•
	Chrome Wine Shelf		○	○	○	NA
	Steel Perforated Plate		○	○	○	○
<b>Electrical</b>	230 V / 50 Hz		•	•	•	•
	220 V / 60 Hz		○	○	○	○
	115 V / 60 Hz	Includes LED lighting	○	○	○	○
<b>Plug</b>	UK (3 Pin) Plug		•	•	•	•
	EU Plug		○	○	○	○



# V60 & V90 Options

## Door styles



Standard



Solid



Fixing point



Frameless

## Handles



Standard



Vertical short



Vertical long



Horizontal short



Horizontal long

## Glass Door options



Standard



Grey tint



Bronze tint



Opaque

## Lighting



Standard  
fluorescent



White LED  
Blue LED  
Red LED  
Green LED

## Shelf options



Chrome wire

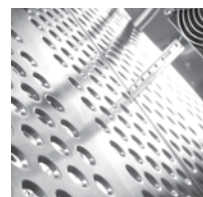

Plate



Chrome wine shelf



*IMC was founded in 1906 and has established itself as a leading manufacturer of commercial catering and bar equipment, with a reputation for quality, innovation and unrivalled customer service.*

*Imperial Machine Company Ltd  
Unit 1 Abbey Road  
Wrexham Industrial Estate  
Wrexham LL13 9RF  
United Kingdom*

*t +44 (0)1978 661155*

*f +44 (0)1978 729990*

*e sales@imco.co.uk*

*w www.imco.co.uk*

***imc***