



Outperform every day.™

Project:

Item Number:

Quantity:

# INTERNATIONAL RETRO STOCK POT KETTLE RETHERMALIZERS



Retro Stock Pot Kettle Rethermalizer

## DESCRIPTION

Vollrath Retro Stock Pot Kettle Rethermalizers, with colorful styling, are designed to increase soup sales at any location. The durable color finishes enhance the presentation. Available in Green Apple, Pearl White, Fire Engine Red, Black Black, or Natural finishes.

Retro Stock Pot Kettle Rethermalizers are shipped complete with inset, cover with hinge, soup cards and card holder. The cover is not NSF.

## PERFORMANCE CRITERIA

The Retro Stock Pot Kettle Rethermalizers are designed to take a container of cooked food from a chilled state (below 40.0° F [4.4° C]) through the HACCP “danger zone” of 165° F (73.9° C) in less than 90 minutes. The performance standard is measured using the NSF mixture chilled to 35° F (1.7° C). The electric unit will raise the temperature of this product above 165° F (73.9° C) in less than 90 minutes. The temperature will be maintained above 150° F (65.6° C) when the food product and pan or inset are used with a standard pan or inset cover, the proper water level is maintained in the well, and the food product is stirred regularly.

## Agency Listings



## WARRANTY

All models shown come with Vollrath’s standard warranty against defects in materials and workmanship. For full warranty details, please refer to [www.Vollrath.com](http://www.Vollrath.com).

Due to continued product improvement, please consult [www.vollrath.com](http://www.vollrath.com) for current product specifications.

## ITEMS

- 7217310 11 Qt. Natural, Schuko Plug
- 7217335 11 Qt. Green Apple, Schuko Plug
- 7217350 11 Qt. Pearl White, Schuko Plug
- 7217355 11 Qt. Fire Engine Red, Schuko Plug
- 7217360 11 Qt. Black, Black, Schuko Plug
- 7217810 7 Qt. Natural, Schuko Plug
- 7217835 7 Qt. Green Apple, Schuko Plug
- 7217850 7 Qt. Pearl White, Schuko Plug
- 7217855 7 Qt. Fire Engine Red, Schuko Plug
- 7217860 7 Qt. Black, Black, Schuko Plug
- 7217410 11 Qt. Natural, UK Plug
- 7217435 11 Qt. Green Apple, UK Plug
- 7217450 11 Qt. Pearl White, UK Plug
- 7217455 11 Qt. Fire Engine Red, UK Plug
- 7217460 11 Qt. Black, Black, UK Plug
- 7217910 7 Qt. Natural, UK Plug
- 7217935 7 Qt. Green Apple, UK Plug
- 7217950 7 Qt. Pearl White, UK Plug
- 7217955 7 Qt. Fire Engine Red, UK Plug
- 7217960 7 Qt. Black, Black, UK Plug

## FEATURES

- Features Vollrath’s Direct Contact Heating System in which the heating element is in direct contact with the water for the most efficient heat transfer possible
- Capillary tube thermostat control supplies constant temperature and power only when needed for maximum power efficiency
- Front access dials for easy temperature setting and maintaining accuracy
- Wide dripless lip catches and drains moisture back into the well and creates more uniform fit with food pans and insets
- Heavy-duty powder-coated aluminum exterior stays cool to the touch
- Non-skid feet help keep unit from sliding on countertop
- Spot welded handles and rolled edges ensure maximum mobility and strength
- Includes cover (item 46527) and low profile inset – item 46407-2 for 7 Qt. or item 46311-2 for 11 Qt. Cover and inset also sold separately.
- Bottom exit 6 ft. (183 cm) power cord adapts to receptacle location for safe installation and allows for 360° control placement

Approvals	Date

The Vollrath Company, L.L.C. Headquarters  
 1236 North 18th Street  
 Sheboygan, Wisconsin  
 53081-3201 USA  
 Main Tel: 800-624-2051 or 920-457-4851  
 Main Fax: 800-752-5620 or 920-459-6573  
 Canada Customer Service: 800-695-8560  
 Tech Services: [techservices@vollrathco.com](mailto:techservices@vollrathco.com)  
[www.vollrath.com](http://www.vollrath.com)

Vollrath Europe BV  
 Beneluxbaan 7  
 5121 AD RIJEN  
 The Netherlands  
 +31161870005

Vollrath of China  
 Vollrath Shanghai Trading Limited  
 23A, Time Square Plaza | 500  
 Zhang Yang Road  
 Pudong, Shanghai 200122  
 Tel: 86-21-50589580

Vollrath de Mexico S. de R.L. de C.V.  
 Periferico Sur No. 7980 Edificio 4-E  
 Col. Santa Maria Tequepexpan  
 45600 Tlaquepaque, Jalisco | Mexico  
 Tel: (52) 333-133-6767  
 Tel: (52) 333-133-6769  
 Fax: (52) 333-133-6768

# INTERNATIONAL RETRO STOCK POT KETTLE RETHERMALIZERS

## DIMENSIONS

(Shown in inches (cm))

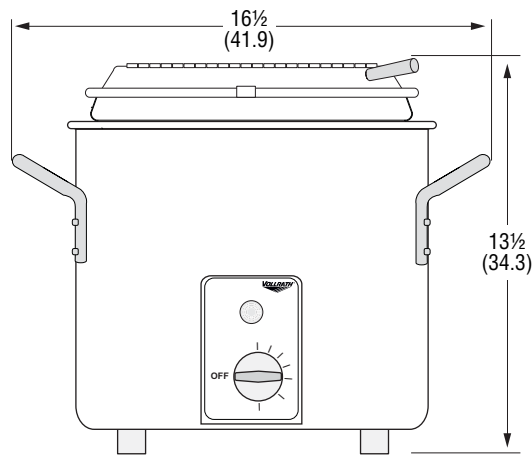

Front View

## SPECIFICATIONS

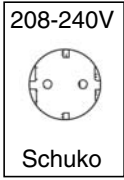
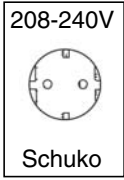
Item No.	Color	Capacity QT (L)	Dimensions (Diameter x Height)	Volts	Watts	Amps	Plug	Shipping Dimensions	Shipping Weight LB (KG)	Receptacles						
7217310	Natural	11 (10.4)	16 1/2 x 13 1/2 (41.9 x 34.3)	230	1400	6.1	Schuko	19 1/8 x 19 1/8 x 14 5/8 (48.6 x 48.6 x 37.1)	19 (8.6)	 Schuko						
7217335	Green Apple															
7217350	Pearl White															
7217355	Fire Engine Red															
7217360	Black, Black															
7217810	Natural	7 (6.6)					16 1/2 x 13 1/2 (41.9 x 34.3)			230	1400	6.1	Schuko	19 1/8 x 19 1/8 x 14 5/8 (48.6 x 48.6 x 37.1)	19 (8.6)	 Schuko
7217835	Green Apple															
7217850	Pearl White															
7217855	Fire Engine Red															
7217860	Black, Black															
7217410	Natural	11 (10.4)											16 1/2 x 13 1/2 (41.9 x 34.3)			230
7217435	Green Apple															
7217450	Pearl White															
7217455	Fire Engine Red															
7217460	Black, Black															
7217910	Natural	7 (6.6)	16 1/2 x 13 1/2 (41.9 x 34.3)	230	1400	6.1		UK	19 1/8 x 19 1/8 x 14 5/8 (48.6 x 48.6 x 37.1)							
7217935	Green Apple															
7217950	Pearl White															
7217955	Fire Engine Red															
7217960	Black, Black															

The Vollrath Company, L.L.C. Headquarters  
 1236 North 18th Street  
 Sheboygan, Wisconsin  
 53081-3201 USA  
 Main Tel: 800-624-2051 or 920-457-4851  
 Main Fax: 800-752-5620 or 920-459-6573  
 Canada Customer Service: 800-695-8560  
 Tech Services: techservice@vollrathco.com  
 www.vollrath.com

Vollrath Europe BV  
 Beneluxbaan 7  
 5121 AD RIJEN  
 The Netherlands  
 +31161870005

Vollrath of China  
 Vollrath Shanghai Trading Limited  
 23A, Time Square Plaza | 500  
 Zhang Yang Road  
 Pudong, Shanghai 200122  
 Tel: 86-21-50589580

Vollrath de Mexico S. de R.L. de C.V.  
 Periferico Sur No. 7980 Edificio 4-E  
 Col. Santa Maria Tequepexpan  
 45600 Tlaquepaque, Jalisco | Mexico  
 Tel: (52) 333-133-6767  
 Tel: (52) 333-133-6769  
 Fax: (52) 333-133-6768